

[47 P] PM

[47 P] PM

SILVER

SILVER

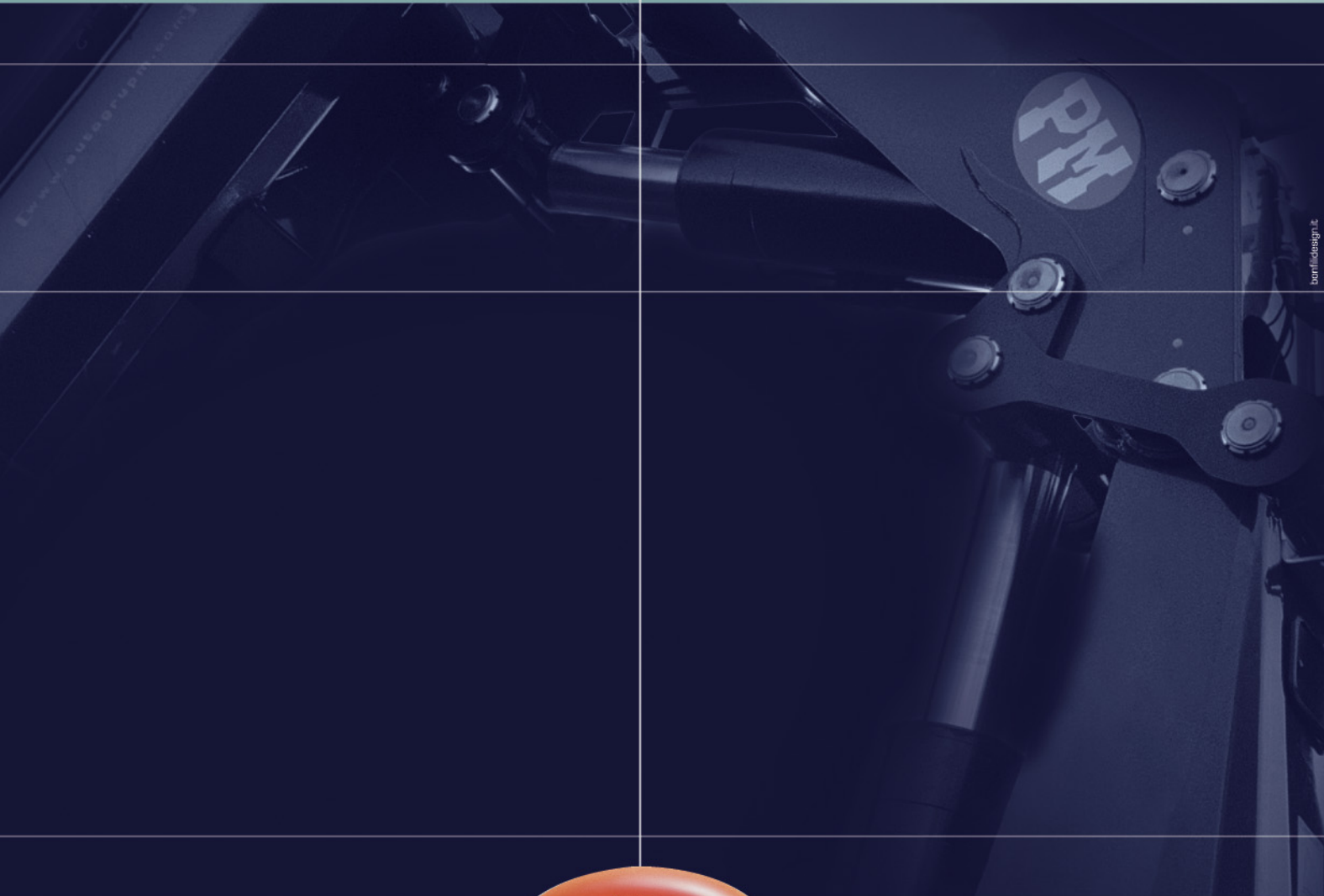

[elevate to the highest power] PM

Brought to you by:
American PM Crane Imports Inc.
Phone# (877) MY-PM-CRANE
(877) 697-6272
Or# (407) 246-1642
Dealer Inquiries Welcome:
Email: Corplnq@PMCranes.Com

Cod. 836.997 E.D. '06

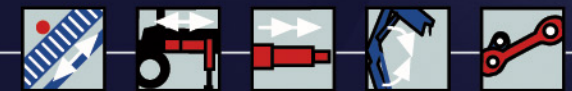

[elevate to the highest power] PM

[47 P] PM

- Sistema PLUS: una riserva di energia per incrementare la potenza fino al 10%
 - PLUS system: extra energy to increase power by up to 10%
- Système PLUS: une réserve d'énergie pour augmenter la puissance jusqu'à 10%
 - PLUS-System: Eine Energiereserve, um die Leistung um bis 10% zu erhöhen
- Sistema PLUS: reserva de energía para incrementar la potencia hasta un 10%

PQS

**SISTEMA DI VERNICIATURA DI QUALITÀ CERTIFICATA
CERTIFIED PAINTING QUALITY SYSTEM
SYSTEME DE VERNISSAGE DE QUALITÉ CERTIFIÉE
ZERTIFIZIERTES QUALITÄTS-LACKIERSYSTEM
SISTEMA DE BARNIZADO DE CALIDAD CERTIFICADA**

- Antenna a 2, 3 e 4 sfili su gru versione 4 e 5 sfili
 - Jib with 2, 3 and 4 extensions on 4 and 5 extension crane version
 - Jib à 2, 3 et coulisses sur grue version 4 et 5 coulisses
 - Jib mit 2, 3 und 4 Ausschüben in der Kranversion mit 4 und 5 Ausschüben
 - Jib con 2, 3 y 4 extensiones en la grúadel model con 4 y 5 extensiones

[3]

**3 ANNI DI GARANZIA SULLE PARTI STRUTTURALI
3 YEARS OF WARRANTY ON THE STRUCTURAL PARTS
3 ANS DE GARANTIE SUR LES PARTIES STRUCTURELLES
3 JAHRE GARANTIE AUF STRUKTURBAUTEILE
3 AÑOS DE GARANTÍA POR LAS PARTES STRUCTURALES**

- Disponibile fino a 6 sfili idraulici
 - Up to 6 hydraulic extensions available
 - Jusqu'à 6 coulisses hydrauliques
 - Bis zu 6 hydraulische Ausschübe erhältlich
 - Disponible hasta 6 extensiones hidráulicas

EN12999

**CONFORME ALLE NORME DI SICUREZZA EU
IN ACCORDANCE TO THE EU SAFETY STANDARDS
CONFORME AUX NORMES DE SECURITE EU
GEMÄß EU SICHERHEITSRICHTLINIEN
CONFORME CON LAS NORMAS DE SEGURIDAD EU**

- Prolunghe manuali su gru ed antenna con dispositivo LMU (opt)
 - Manual extensions on crane and jib with LMU device (opt)
 - Rallonges manuelles sur grue et antennes avec dispositif LMU (opt)
 - Manuelle Verlängerungen am Kran und Zusatzknickarm mit LMU-Vorrichtung (opt)
 - Prolongas manuales sobre la grúa y antenas con dispositivo LMU (opt)

- Uscita sequenziale sfilo bracci
 - Extention sequence boom
- Sortie vérin télescopique en séquence
 - Ausschubzylinder-Sequenz
 - Salida secuencial de los brazos

- Bracci stabilizzatori a sfilo idraulico allargabili fino a 7,3 m
 - Stabilizers with hydraulic extension, extendable up to 7,3 m
 - Bras stabilisateurs à coulisse hydraulique, élargissable jusqu'à 7,3 m
 - Stützarme mit hydraulischem Ausschub, ausziehbar bis auf 7,3 m
 - Brazos estabilizadores con extensión hidráulica que ofrecen un alcance máximo de 7,3 m

LIAT

**DICHIARAZIONE DI CONFORMITÀ DEL PRODUTTORE
DECLARATION OF CONFORMITY OF THE MANUFACTURER
DECLARATION DE CONFORMITE DU PRODUCTEUR
KONFORMITÄTserklärung DES HERSTELLERS
DECLARACIÓN DE CONFORMIDAD DEL PRODUCTOR**



ACCESSORI - ACCESSORIES - ACCESSOIRE - ACCESSORIOS - ZUBEHÖRE



Radiocomando multifunzione Scanreco/Hetronic.
Scanreco/Hetronic multifunction radio control.
Radiocommande multifonctions Scanreco/Hetronic.
Multifunktions-Fernbedienung Scanreco/Hetronic.
Radiocontrol multifunción Scanreco/Hetronic.

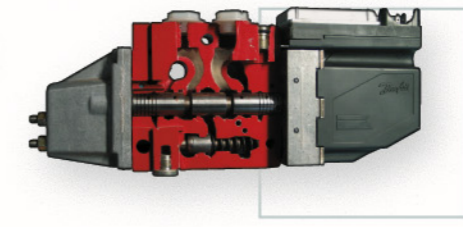

Distributore proporzionale DANFOSS.
Danfoss proportional hydraulic control valve block.
Distributeur hydraulique proportionnel Danfoss.
Proportionaler Steuerventilblock Danfoss.
Distribuidor hidráulico proporcional Danfoss.

Scambiatore di calore
Heat exchanger
Wärmetauscher
Échangeur de chaleur
Cambiador de calor



Verricello idraulico da 1500 kg su antenna, fino a 2000 Kg su gru.
Hydraulic winches with a capacity ranging from 1500 kg on jibs, up to 2000 kg on crane.
Treuils hydrauliques de 1500 kg sur fléchette, jusqu'à 2000 kg sur la grue.
Hydraulische Winden von 1500 kg (Jib), bis 2000 kg (Kran)
Cabrestantes hidráulicos de 1500 kg en Jib, a 2000 kg en grúa



Posto di manovra in piedi: massimo angolo di visibilità.
Raised control station: maximum angle of visibility
Poste de manoeuvre debout: angle maximum de visibilité.
Steuer-Stehplatz Optimaler weiter Blickwinkel.
Puesto de maniobra en pie: máximo ángulo de visibilidad.

Attivazioni alimentate con avvolgitubi
Activations powered by means of hose winder
Commandes alimentées avec enrouleurs de tuyaux
Aktivierungen mit Speisung über Schlauchwinden
Activaciones alimentadas con arrolladores de tubos



Cremaigliera
Slewing by rack
Rotation avec crémaillère
Schwenkung mittels Zahnstange
Rotación con cremallera de giro

Mono biella
Single connecting rod
Doubles biellettes sur une articulation
Kniehebel
Biela Simple

Bracci stabilizzatori a sfilo idraulico
Hydraulic outrigger booms
Bras stabilisateur à extension hydraulique
Hydraulischer Abstützausschub
Brazos estabilizadores a salida hidráulica

Uscita sequenziale sfilo bracci
Extention sequence boom
Sortie vérin télescopique en séquence
Ausschubzylinder-Sequenz
Salida secuencial de los brazos

Kit valvola di blocco rotazione
Slewing valve
Soupape d'arrêt rotation
Drehventil
Kit bloqueo de rotación

SILVER

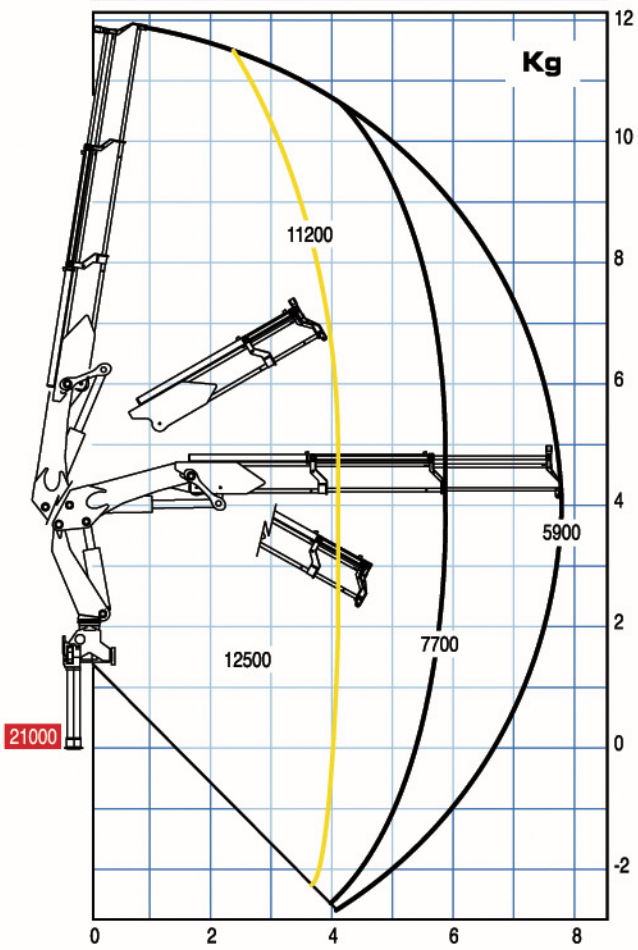
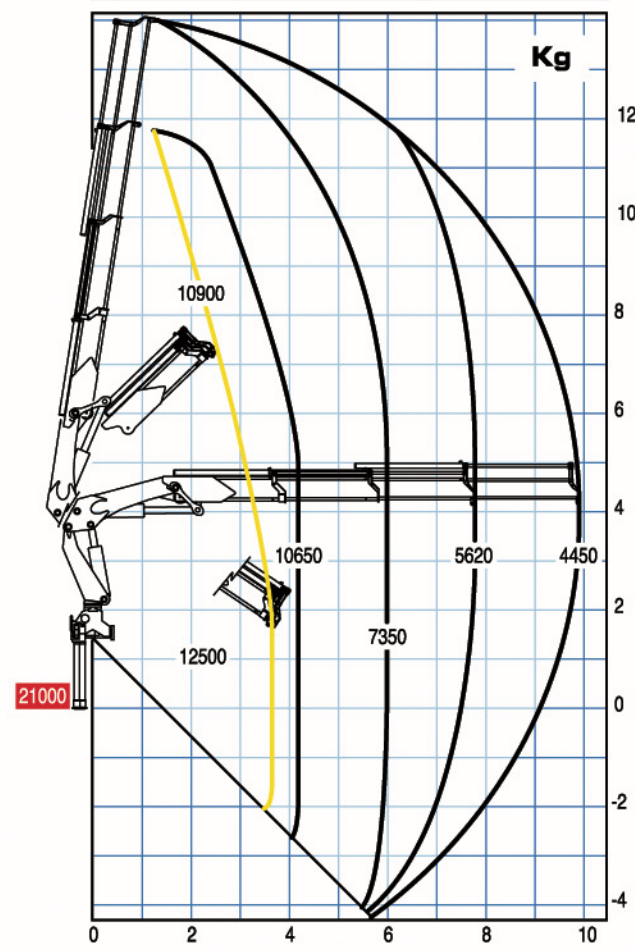
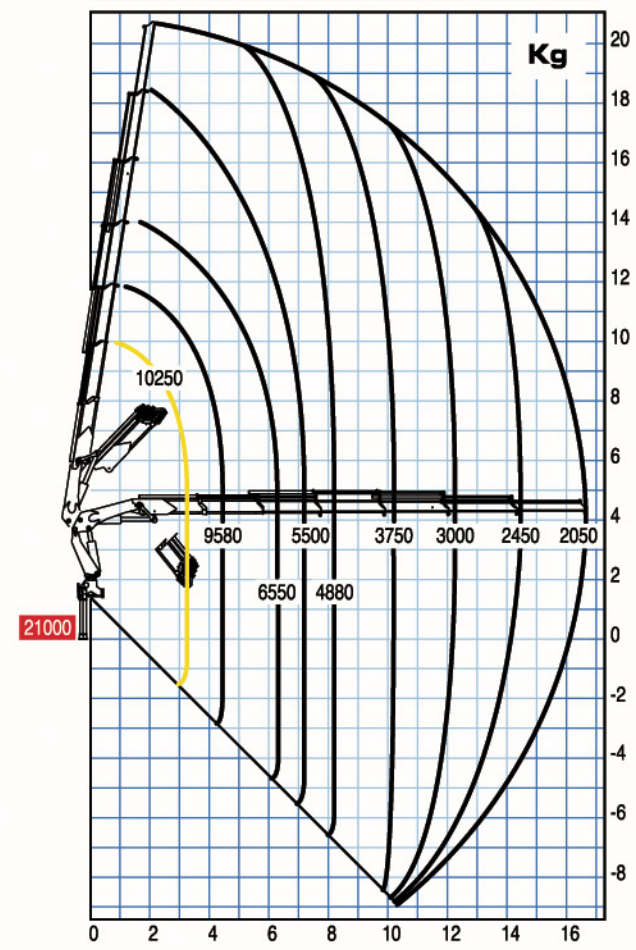
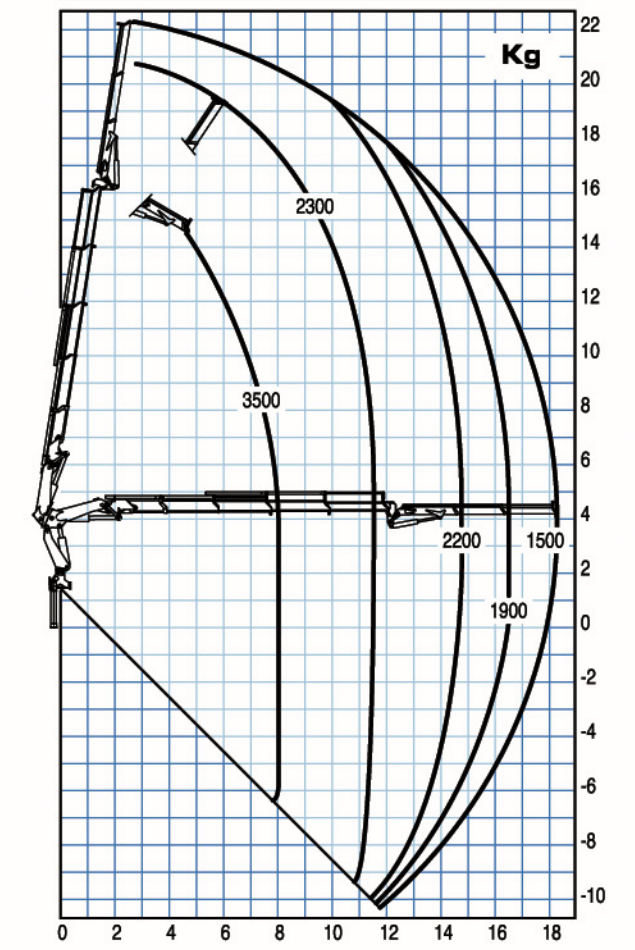
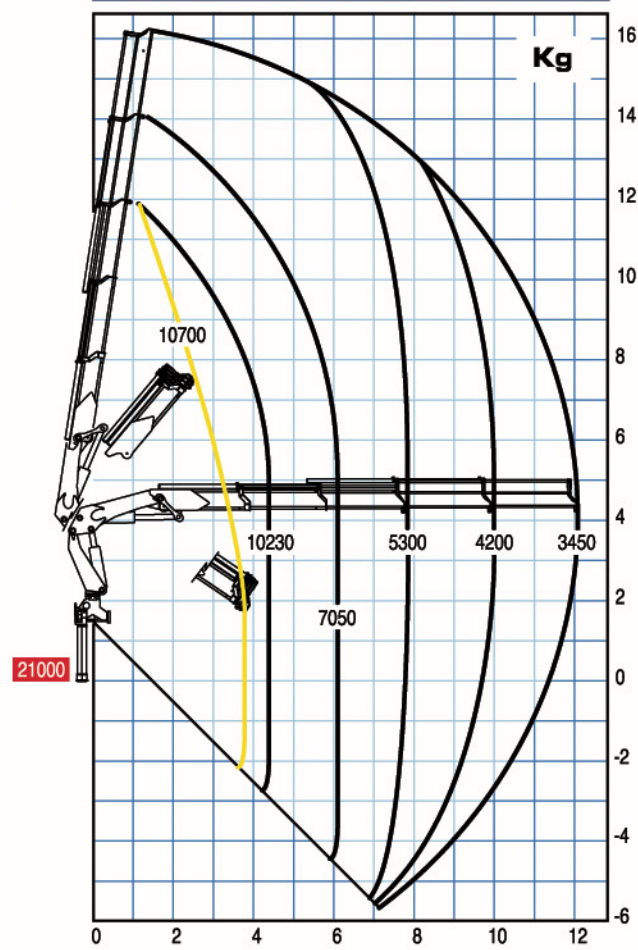
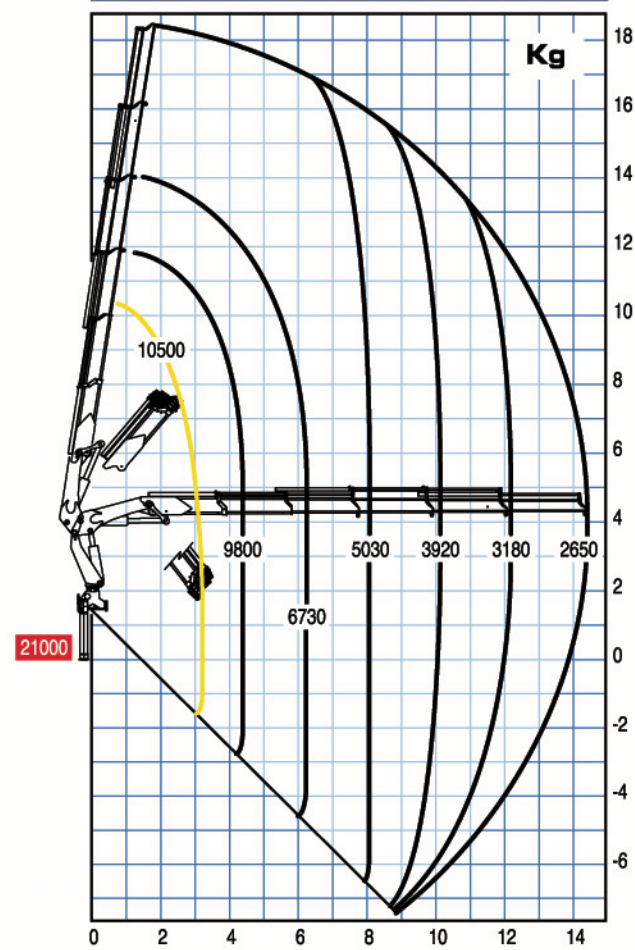
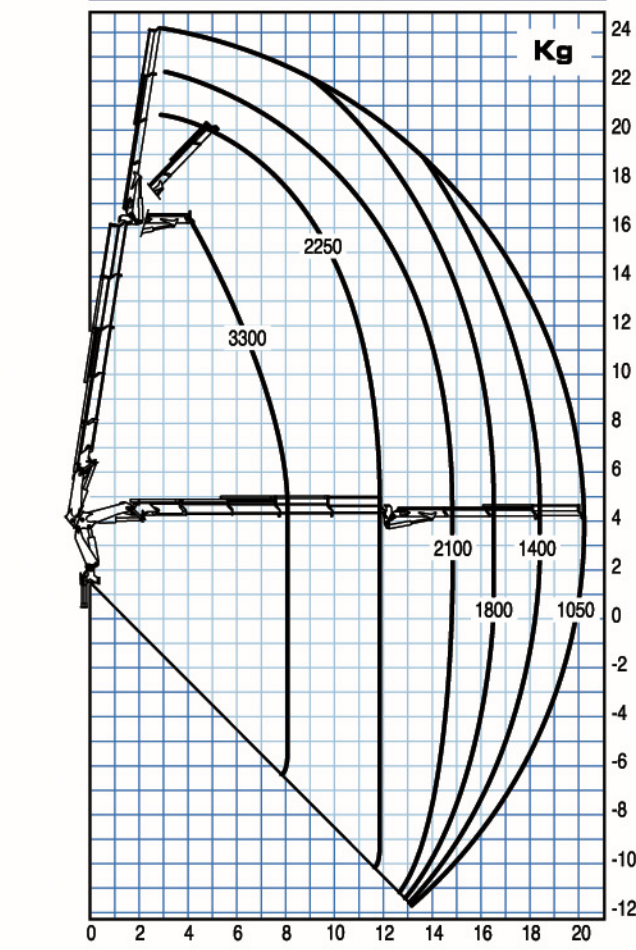
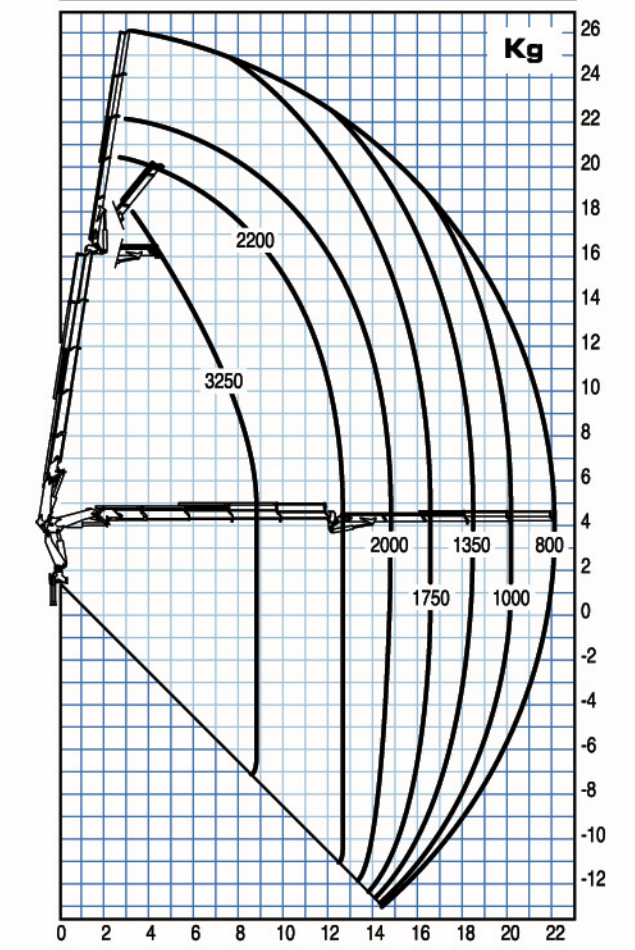
47022 P**47023 P****47026 P****47024 P + J92****47024 P****47025 P****47024 P + J93****47024 P + J94L**

— Portata massima passante per l'orizzontale - Max. capacity from horizontal to vertical - Capacité maxi passant par l'horizontale - Max. Tragkraft von horizontal bis zu vertical - Capacidad máxima en posición vertical
 ■ Portata massima nominale al gancio fisso - Max. nominal capacity with fixed hook - Capacité maxi nominale au crochet fixe - Max. Nenntragkraft an der inneren Hakenbefestigung - Capacidad máxima en el gancho fijo

47025 P + J92

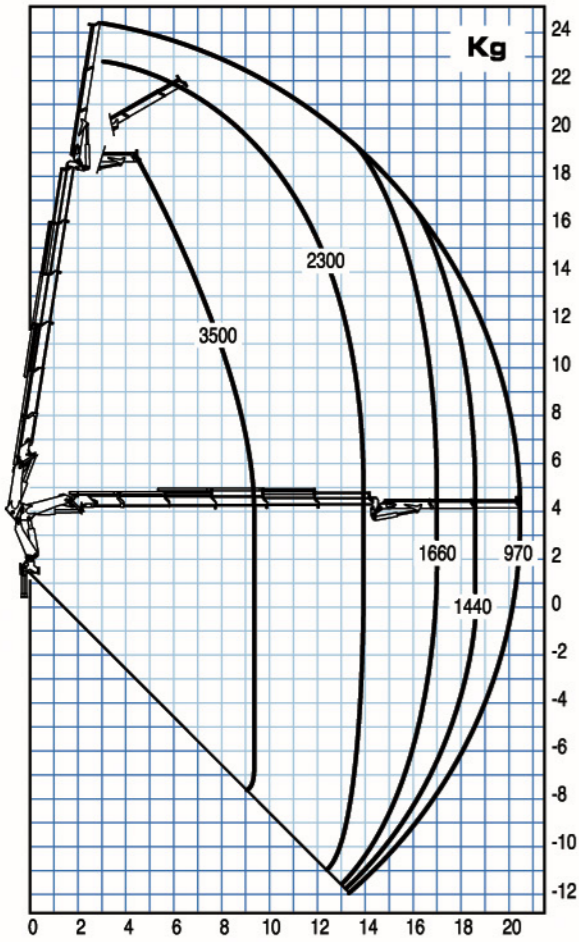

47025 P + J93

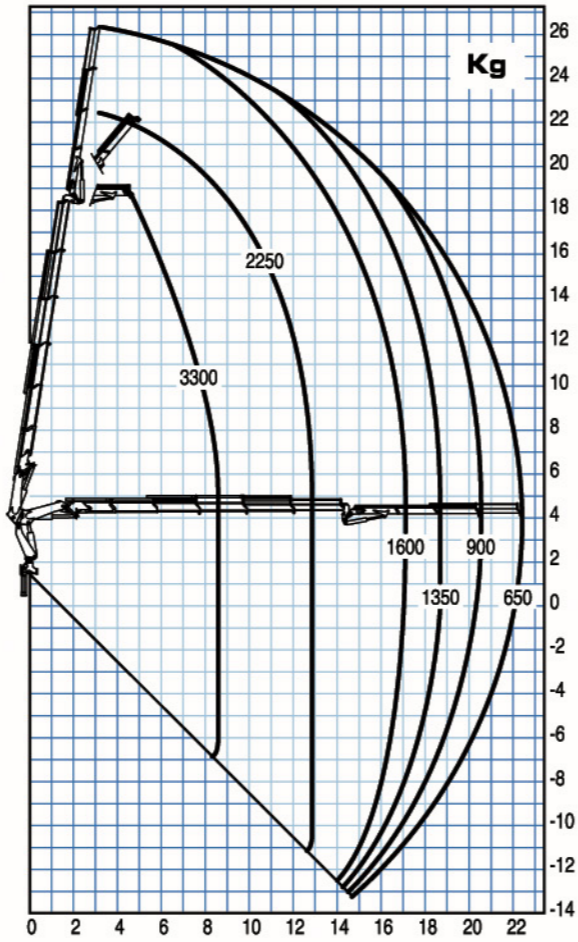

47025 P + J94L

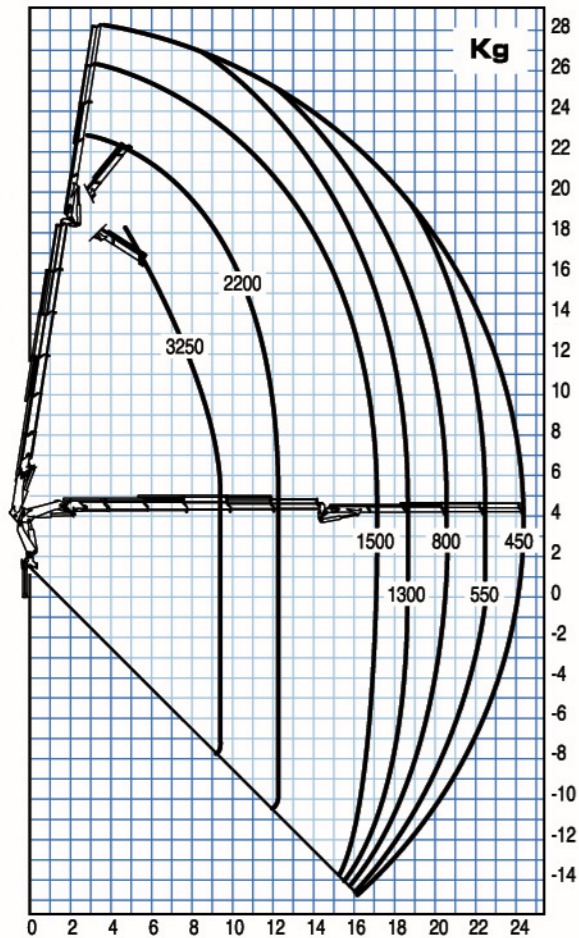

Tutte le gru PM sono coperte da polizza assicurativa internazionale per la responsabilità verso terzi.
All PM Cranes are covered by international insurance policy for civil liability third party.
Toutes les grues sont couvertes par une police d'assurance internationale de responsabilité civile envers tiers.
PM-Kränes sind durch eine internationale haftpflichtversicherung gegen dritte abgesichert.
Todas las grúas PM cuentan con una póliza de seguros internacional contra las responsabilidades civiles hacia terceros.

I dati tecnici possono essere aggiornati senza preavviso.
Technical data can be revised without prior notice.
Les données techniques peuvent être modifiées sans préavis.
Technische Änderungen vorbehalten.
Reservado el derecho de modificaciones.

Abbinamento gru/veicolo - Trucking crane combination -
Accouplement grue/véhicule - Kran zusammen mit LKW -
Acoplamiento grúa con vehículo

- | | | |
|----------|-----|------------------|
| PTT/GVW | 47P | 4 stabilizzatori |
| 26,0 ton | | 4 outriggers |
| 32,0 ton | | 4 stabilisateurs |
| 44,0 ton | | 4 abstützungen |
| | | 4 gatos de apoyo |

PTT: Peso totale a terra - G.V.W. - P.T.A.C. - LKW Gesamtgewicht
Peso total del vehículo

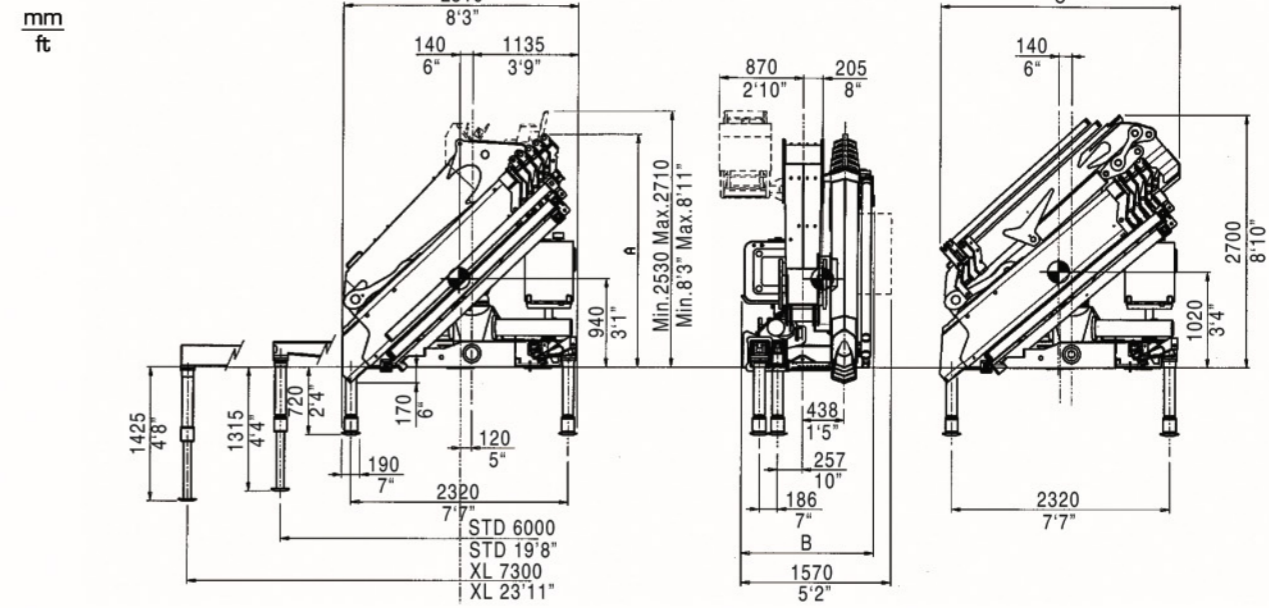
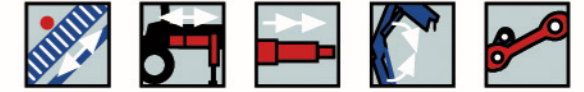

	47022P	47023P	47024P	47025P	47026P
A (mm)	2415	2415	2415	2415	2465
A (ft)	7'11"	7'11"	7'11"	7'11"	8'1"
B (ft)	1335	1335	1385	1385	1385
B (ft)	4'4"	4'4"	4'6"	4'6"	4'6"

	47024P+J92	47024P+J93	47024P+J94L	47025P+J92	47025P+J93	47025P+J94L
C (mm)	2540	2550	2600	2540	2550	2600
C (ft)	8'4"	8'4"	8'6"	8'4"	8'4"	8'6"

	47022 P	47023 P	47024 P	47025 P	47026 P	47024 P +J92	47024 P +J93	47024 P +J94L	47025 P +J92	47025 P +J93	47025 P +J94L	
Momento di sollevamento massimo - Maximum lifting moment - Moment de levage maxi - Max. Lastmoment - Momento del elevación máxima	tm kNm	45,8 449	44,2 433	43,5 427	42,8 420	42,5 417	-	-	-	-	-	
Sbraccio oleodinamico - Maximum hydraulic reach - Allongement hydraulique - Hydraulische reichweite, Standard - Alcance hidráulico - horizontal - horizontal - horizontal - horizontal - vertical - vertical - vertical - vertikál - vertical	m m	7,95 11,50	10,10 13,60	12,25 15,80	14,55 17,90	16,85 20,40	18,50 21,90	20,40 23,80	22,30 25,70	20,70 24,10	22,60 26,00	24,50 27,90
Sbraccio con prolunghe - Maximum reach with manual extensions - Allongement avec rallonges manuelles - Reichweite, manuelle Verlängerungen - Alcance con prolongas manuales - horizontal - horizontal - horizontal - horizontal - vertical - vertical - vertical - vertikál - vertical	m m	-	-	20,50 23,90	22,40 25,40	22,40 25,40	-	26,10 29,50	26,00 29,40	-	28,30 31,70	28,20 31,60
Impianto oleodinamico - Hydraulic system - Circuit hydraulique - Hydraulikanlage - Sistema hidráulico portata raccomandata - recommended oil flow - débit recommandé - empfohlene fördermenge - caudal requerido	l/min	50	50	50	50	50	50	50	50	50	50	
pressione massima - rated pressure - pression maxi - betriebsdruck - presión máxima	Mpa	29,5	29,5	29,5	29,5	29,5	29,5	29,5	29,5	29,5	29,5	
capacità del serbatoio - tank capacity - capacité du réservoir - tankinhalt - capacidad del depósito de aceite	l	200	200	200	200	200	200	200	200	200	200	
Gruppo di rotazione - Slewing system - Rotation - Schwenksystem - Sistema de giro	°	385	385	385	385	385	385	385	385	385	385	
coppia di rotazione - slewing moment - couple de rotation - schwenkmoment - momento de giro	kNm	46	46	46	46	46	46	46	46	46	46	
pendenza massima di lavoro - max. working heel - devers maxi - de travail - maxi arbeitsneigung - inclinación máxima de trabajo	%(°)	8,7(5)	8,7(5)	8,7(5)	8,7(5)	8,7(5)	0	0	0	0	0	
Peso della gru standard - Standard crane weight - Poids de la grue standard - Eigengewicht - Peso de la grúa est.	kg	4380	4630	4870	5110	5310	5440	5550	5630	5690	5800	5870
Con serbatoio non rifornito - Empty oil tank - reservoir huile non garni - oeltank leer - depósito de aceite vacío	kg	4380	4630	4870	5110	5310	5440	5550	5630	5690	5800	5870



47022 P



47023 P

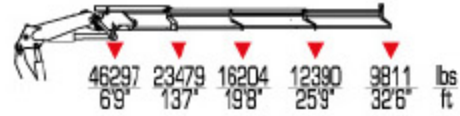

47024 P

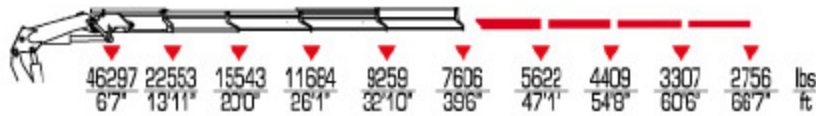

47025 P

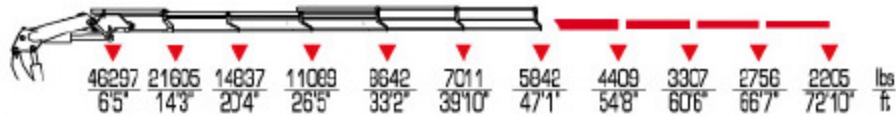

47026 P

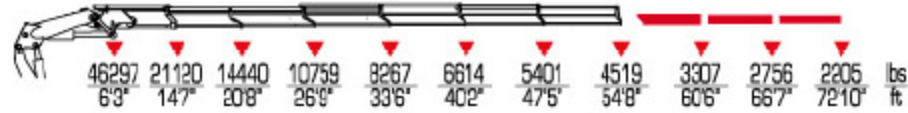

47024 P + J92



47024 P + J93



47024 P + J94L



47025 P + J92



47025 P + J93

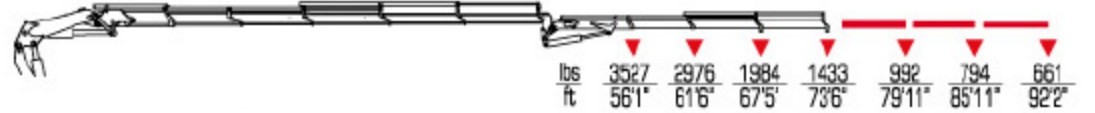

47025 P + J94L

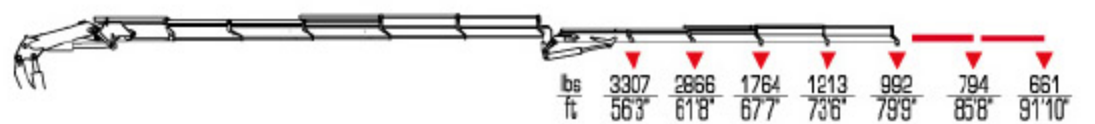

	ft lbs	gals /min	Psi	°	lbs	ST	8'3"	7'11"	4'4"	
47022 P	331270	13	4280	385	9612		8'3"	7'11"	4'4"	47022 P
47023 P	319700	13	4280	385	10163		8'3"	7'11"	4'4"	47023 P
47024 P	314640	13	4280	385	10692		8'3"	7'11"	4'6"	47024 P
47025 P	309570	13	4280	385	11222		8'3"	7'11"	4'6"	47025 P
47026 P	307400	13	4280	385	11662		8'3"	8'1"	4'6"	47026 P
47024 + J92	-	13	4280	385	11949		8'4"	8'10"	5'2"	47024 + J92
47024 + J93	-	13	4280	385	12192		8'4"	8'10"	5'2"	47024 + J93
47024 + J94L	-	13	4280	385	12368		8'6"	8'10"	5'2"	47024 + J94L
47025 + J92	-	13	4280	385	12478		8'4"	8'10"	5'2"	47025 + J92
47025 + J93	-	13	4280	385	12721		8'4"	8'10"	5'2"	47025 + J93
47025 + J94L	-	13	4280	385	12897		8'6"	8'10"	5'2"	47025 + J94L