

[41 s] PM

[41 s] PM

[it] [en]

SILVER

[it] [en]

SILVER

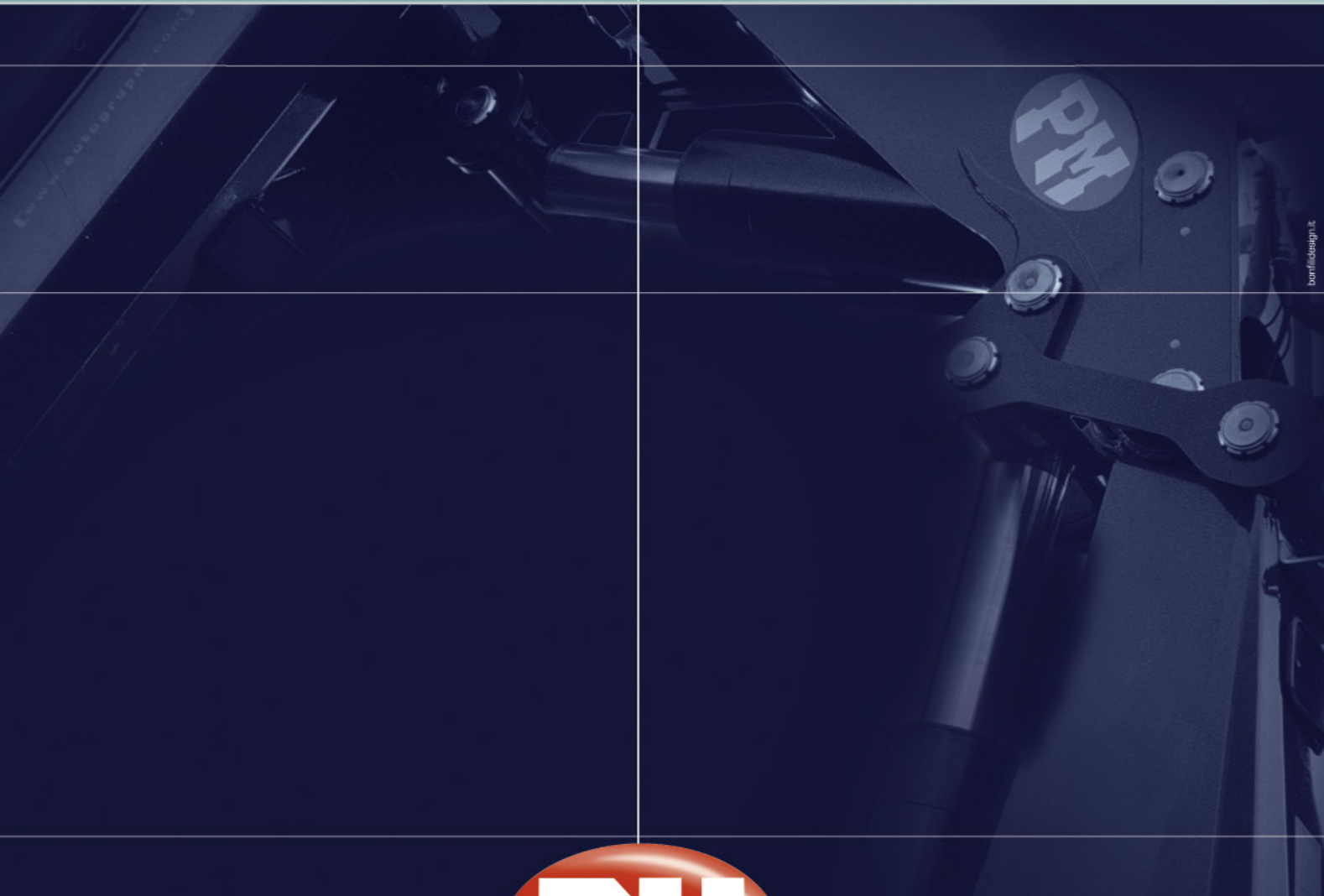

[elevate to the highest power] PM

Brought to you by:  
American PM Crane Imports Inc.  
Phone# (877) MY-PM-CRANE  
(877) 697-6272  
Or# (407) 246-1642  
Dealer Inquiries Welcome:  
Email: [Corplnq@PMCranes.Com](mailto:Corplnq@PMCranes.Com)

Cod. 856.895 ED. 107



[elevate to the highest power] PM



## POTENTE ED AFFIDABILE PER OGNI IMPIEGO - POWERFUL AND RELIABLE FOR EVERY USE

### Optional

- Radiocomando multifunzione di serie Scanreco/Hetronic.
- Scanreco/Hetronic multifunction radio remote control.



**SISTEMA DI VERNICIATURA DI QUALITÀ CERTIFICATA  
CERTIFIED PAINTING QUALITY SYSTEM**



- DOPPIE BIELLE SUGLI SNODI PER MOVIMENTI COSTANTI E DI PRECISIONE.
- DOUBLE CONNECTING RODS ON THE POINTS OF ARTICULATION TO ENSURE CONSTANT AND ACCURATE MOVEMENTS.

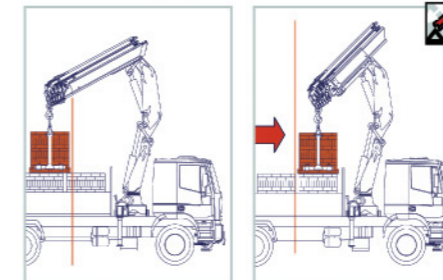

- Gru PM, versione LC, con primo braccio retraibile idraulicamente, agevola le movimentazioni ingombranti e gravose a corto raggio, ottimizzando anche le posizioni di carico sotto colonna.
- PM crane in LC version, with first hydraulic retractable boom, optimizes the load positioning close to the column, and makes easy the placement of heavy and bulky loads.

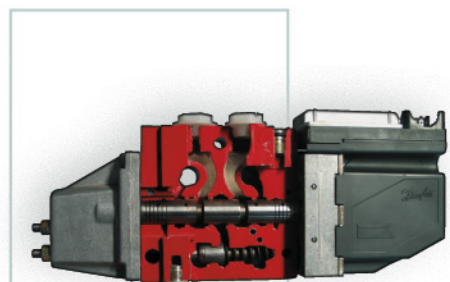

- Distributore proporzionale DANFOSS.
- DANFOSS proportional hydraulic control valve block.



**DICHIARAZIONE DI CONFORMITÀ DEL PRODUTTORE  
DECLARATION OF CONFORMITY OF THE MANUFACTURER**



- Attivazioni alimentate con avvolgitubi
- Activations powered by means of hose winder.



- Verricello idraulico da 800 kg su antenna, fino a 1500 su gru.
- Hydraulic winches with a capacity ranging from 800 kg on jibs, up to 1500 kg on crane.



- Scambiatore di calore
- Heat exchanger



**3 ANNI DI GARANZIA SULLE PARTI STRUTTURALI  
3 YEARS OF WARRANTY ON THE STRUCTURAL PARTS**



**CONFORME ALLE NORME DI SICUREZZA EU  
IN ACCORDANCE TO THE EU SAFETY STANDARDS**

- DISPONIBILE FINO A 8 ESTENSIONI IDRAULICHE con dispositivo di uscita sfilì sequenziale garantita per massima velocità e tutela dell'integrità del braccio stesso.
- UP TO 8 HYDRAULIC EXTENSIONS AVAILABLE with sequential extension exit device guaranteed for maximum speed and protection of integrity of the boom itself.

Cremagliera  
Slewing by rack



Bracci stabilizzatori a sfilò idraulico  
Hydraulic outrigger booms



Uscita sequenziale sfilò bracci  
Extension sequence boom



Kit valvola di blocco rotazione  
Slewing valve



Doppia biella  
Double connecting rods



Configurazione LC  
LC execution



41022 S - 41022 S LC

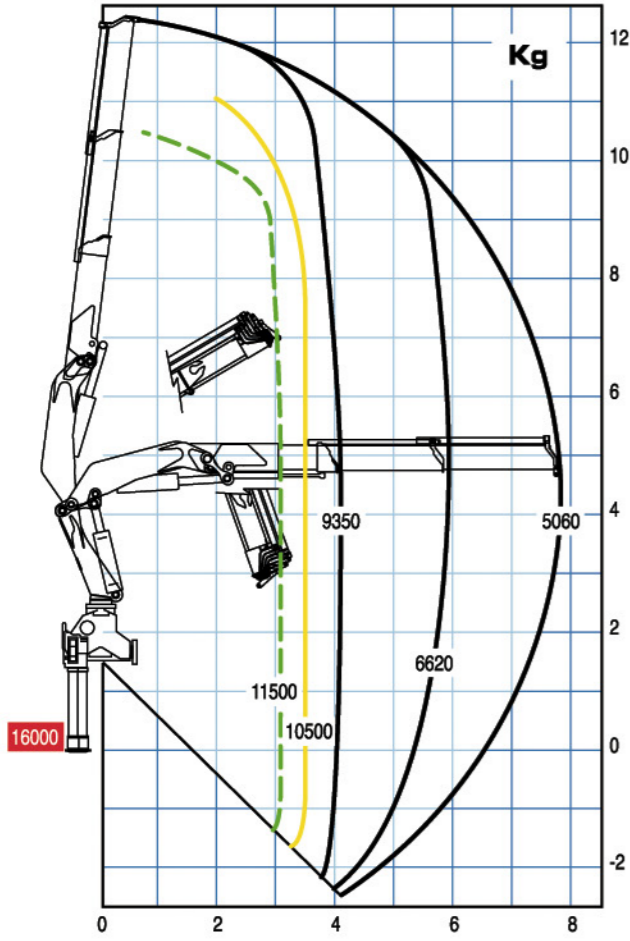

41023 S - 41023 S LC

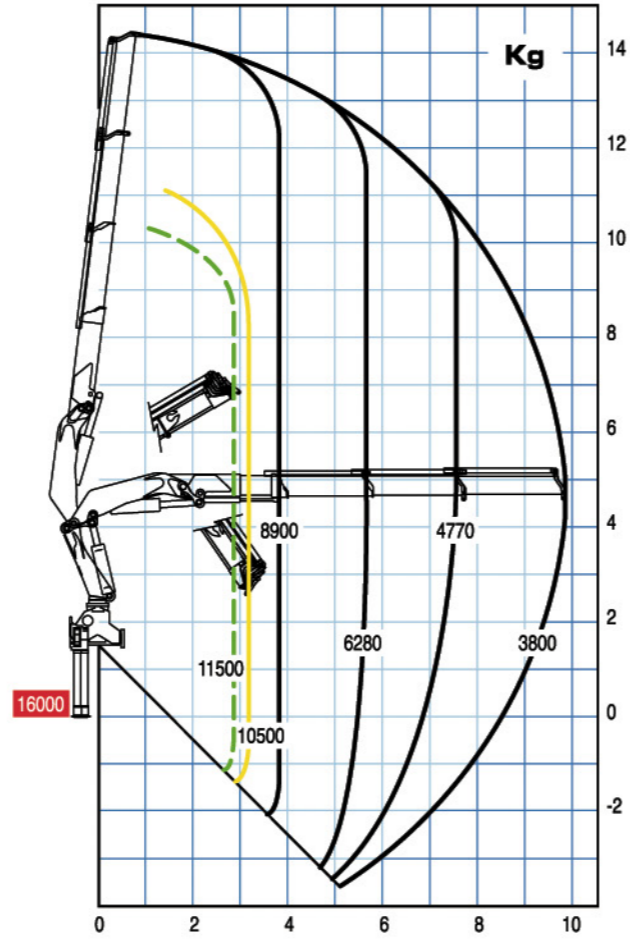

41026 S - 41026 S LC

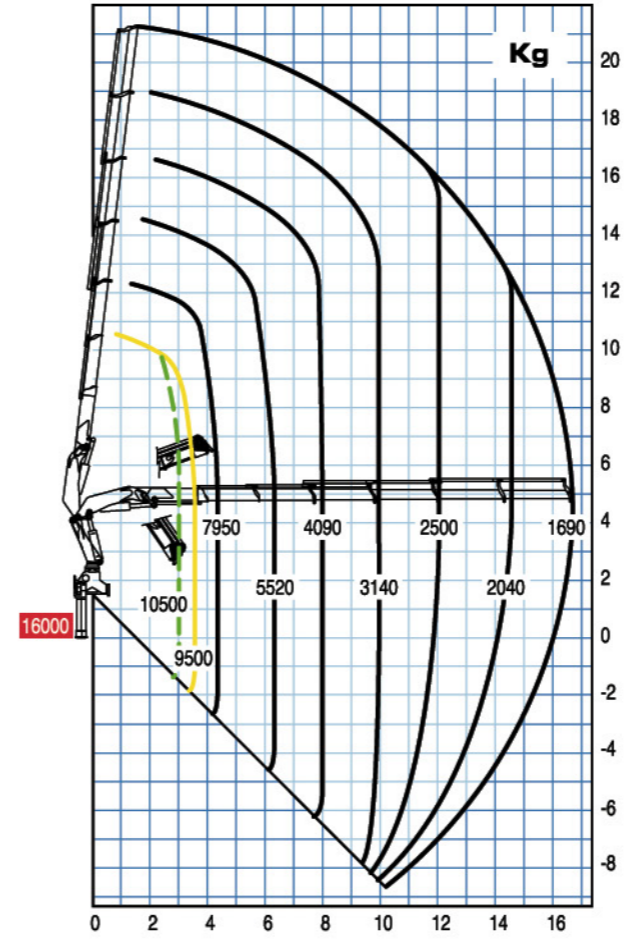

41027 S - 41027 S LC

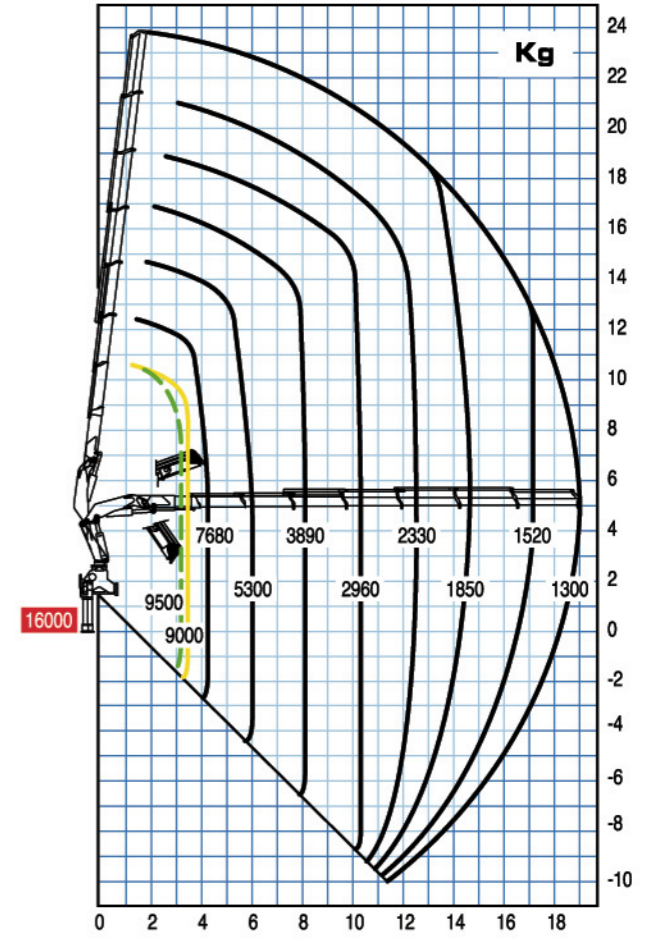

41024 S - 41024 S LC

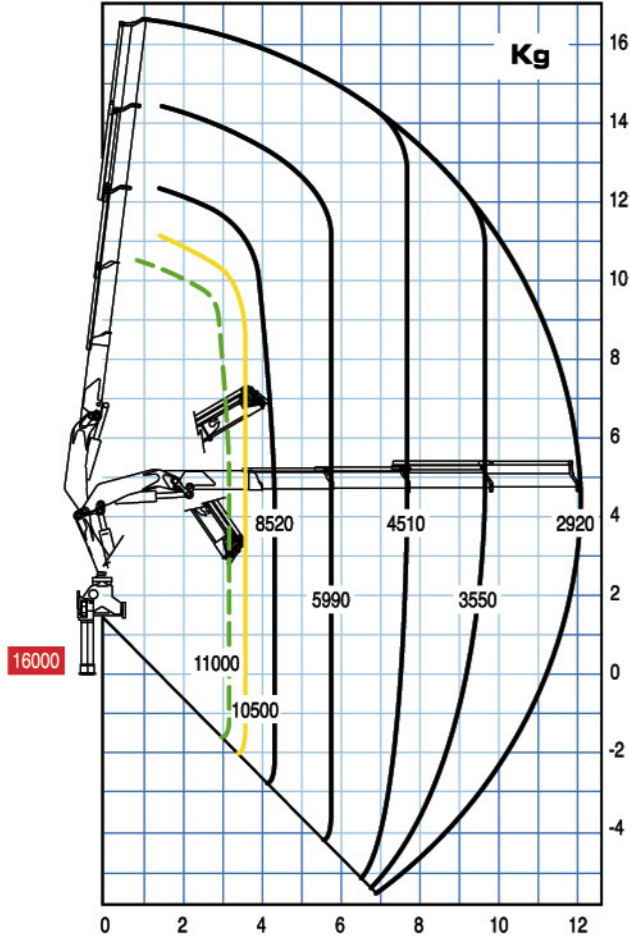

41025 S - 41025 S LC

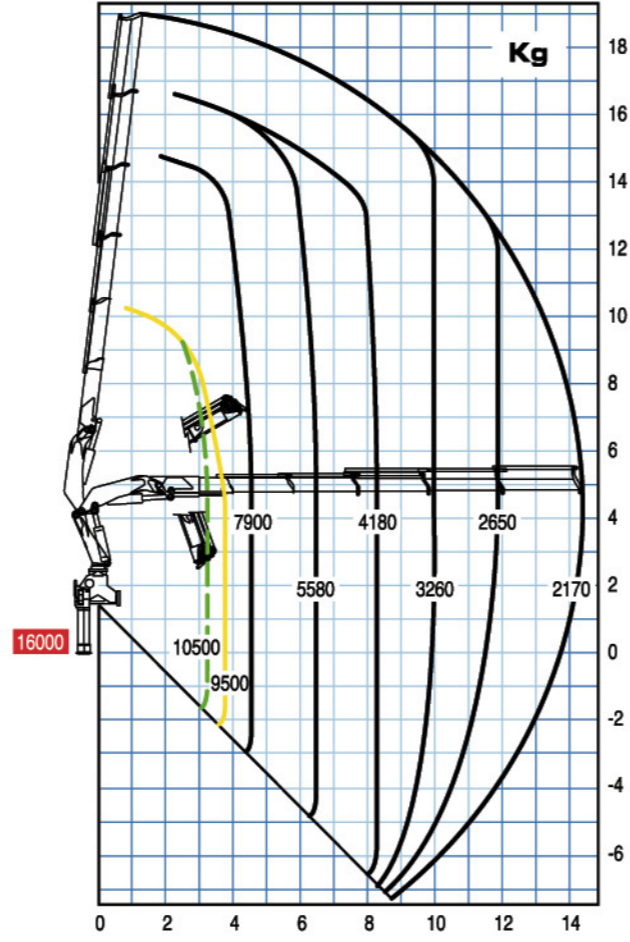

41028 S - 41028 S LC

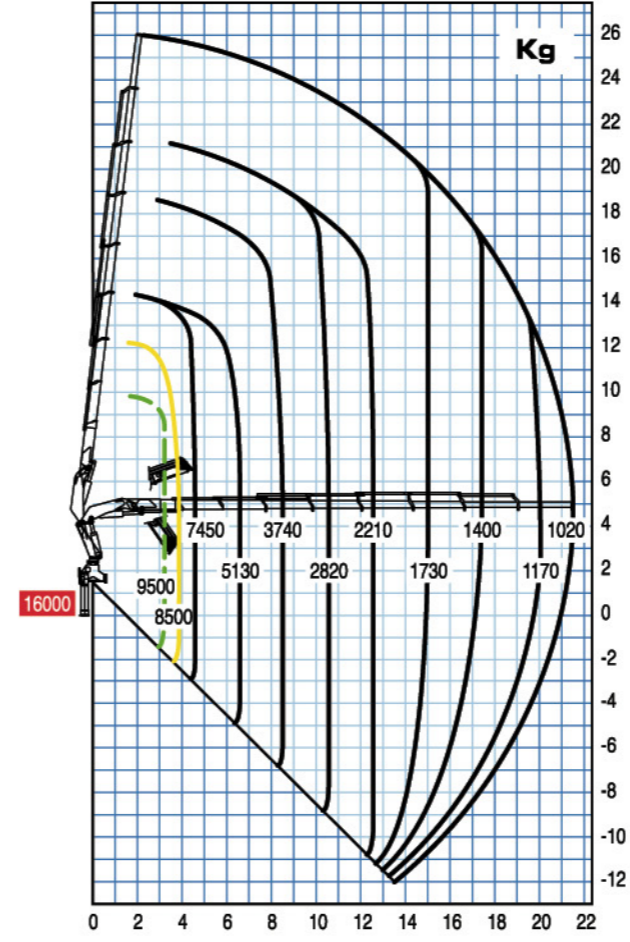

41024 S + J903

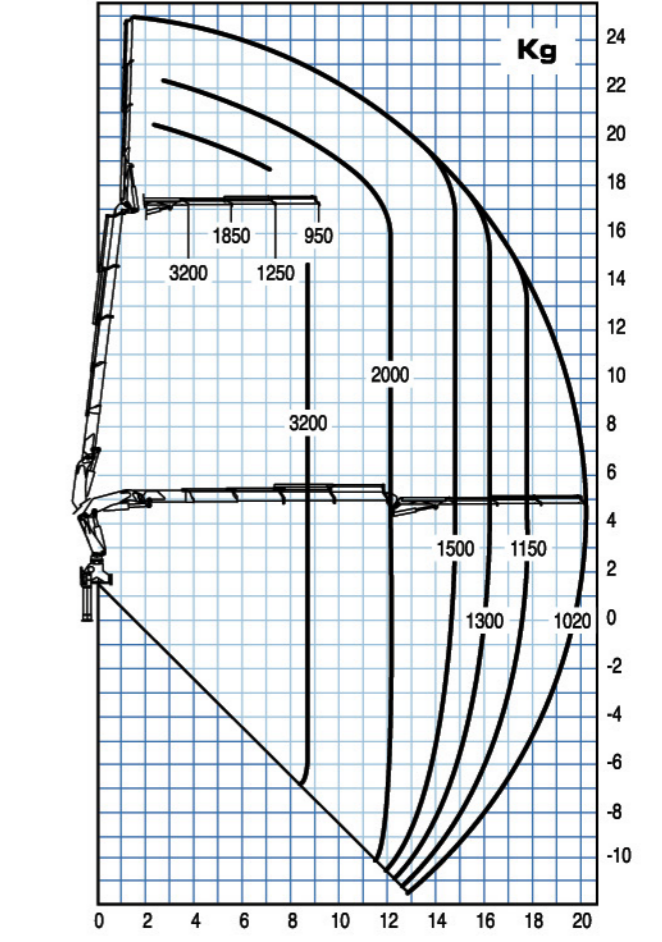

— Portata massima passante per l'orizzontale - Max. capacity from horizontal to vertical  
 ■ Portata massima nominale al gancio fisso - Max. nominal capacity with fixed hook

— Solo con gru in versione LC  
 ■ Only LC crane version

41024 S + J904

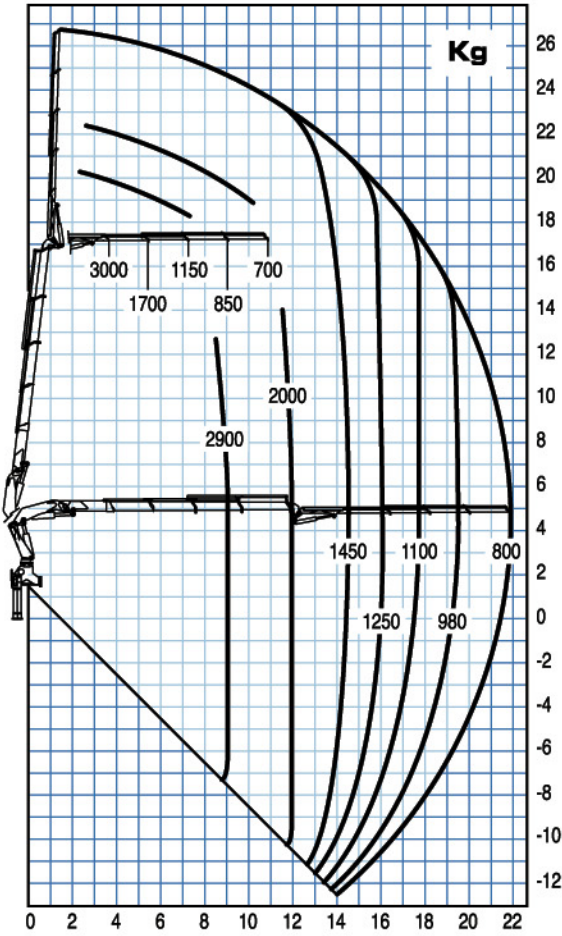

41025 S + J903

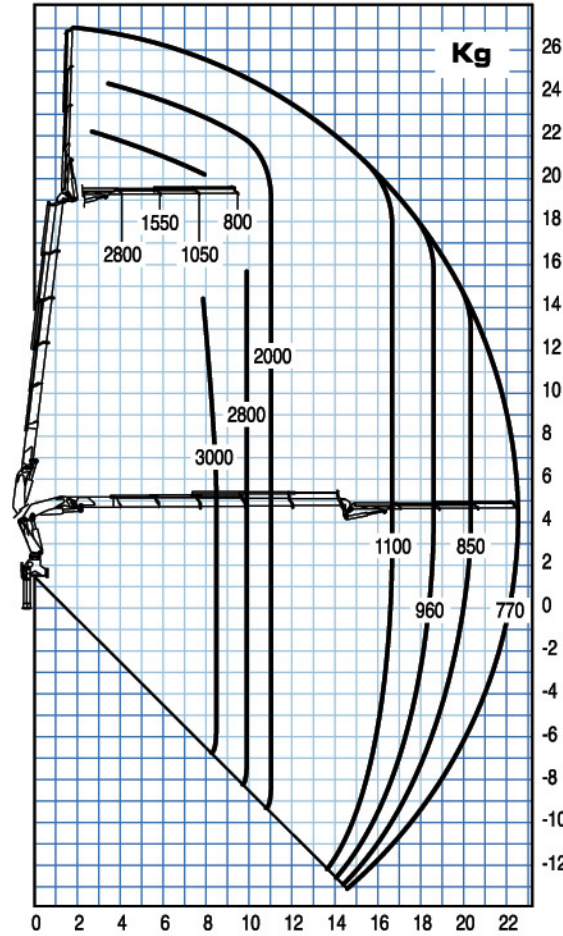

41025 S + J904

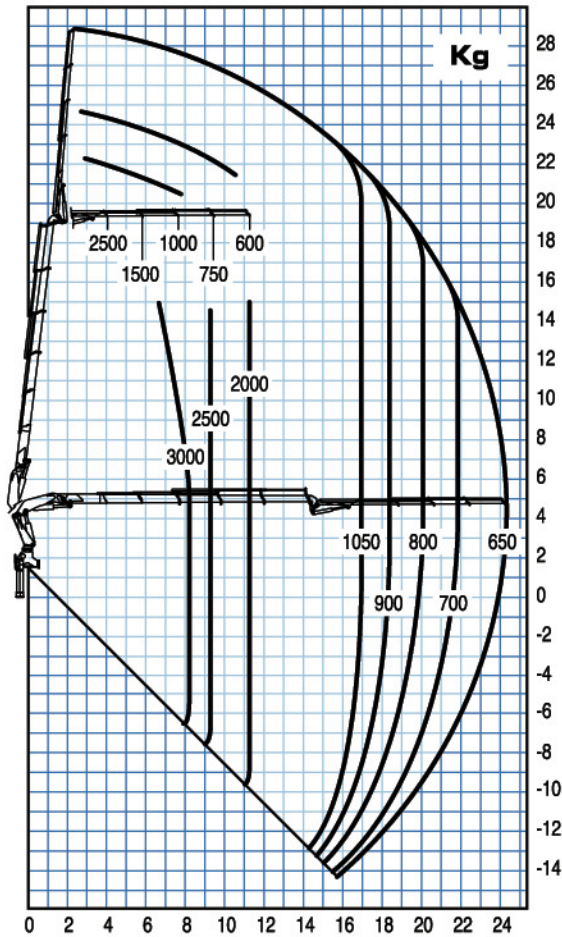

41026 S + J703

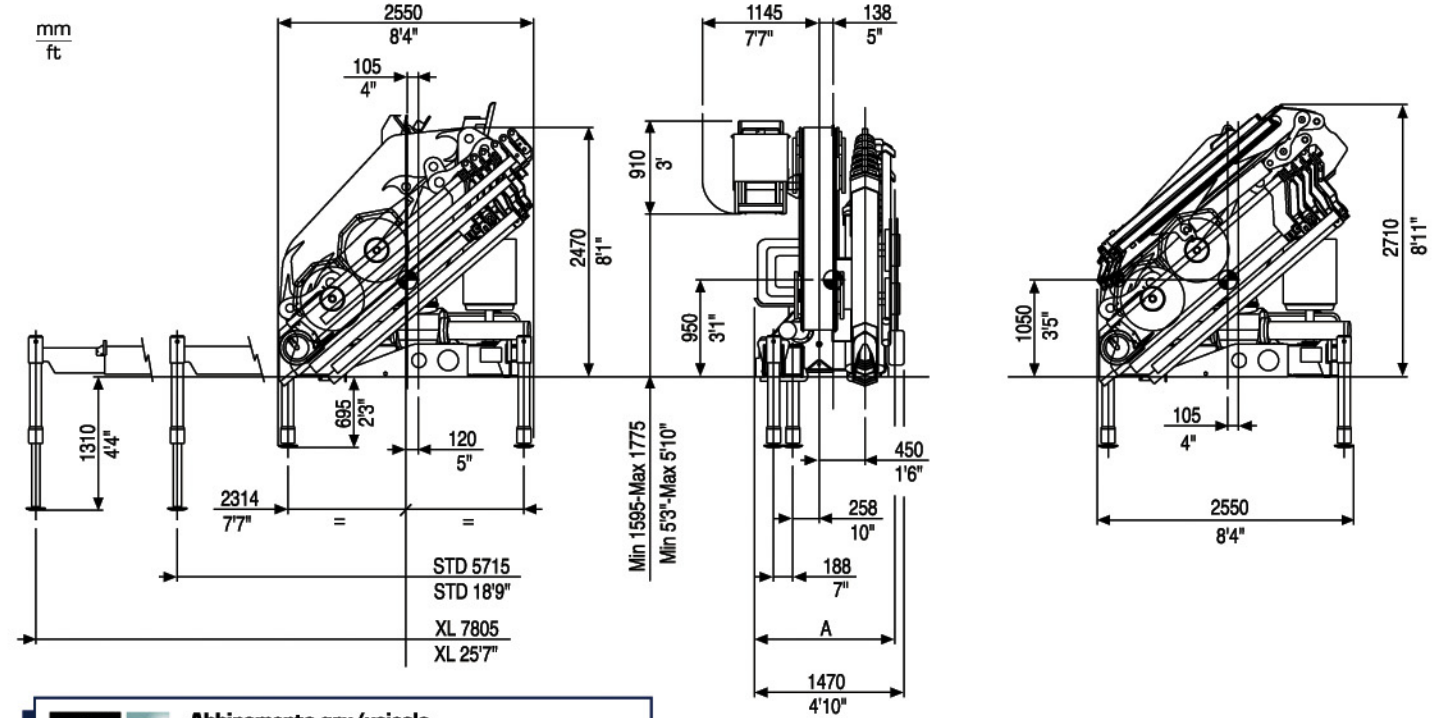
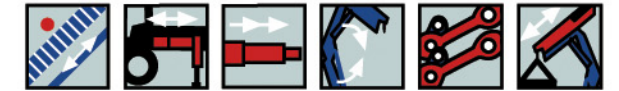
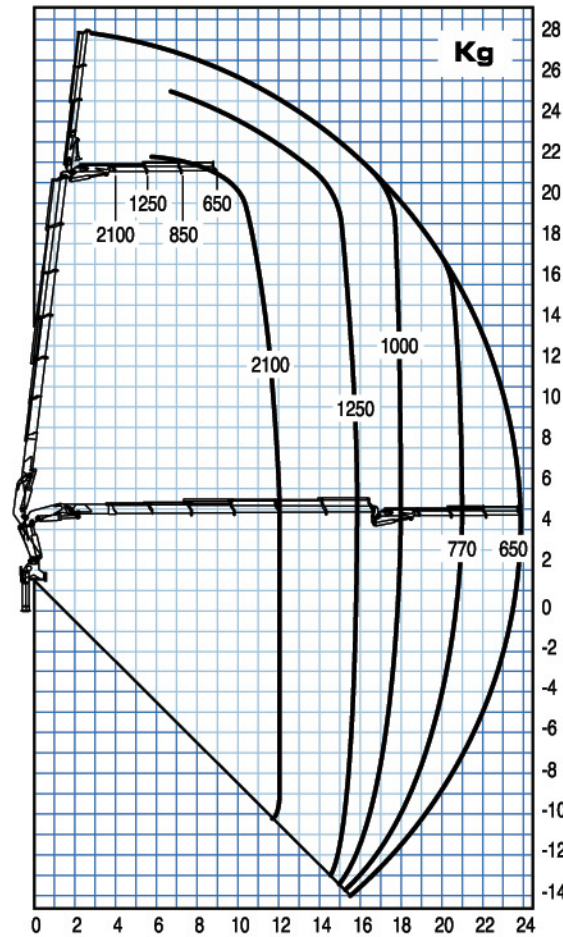

**PTT/GVW 41 S** **Abbinamento gru/veicolo**  
**Trucking crane combination**

26,0 ton		4 stabilizzatori 4 outriggers
32,0 ton		
44,0 ton		

**PTT:** Peso totale a terra - G.V.W.

	41022	41023	41024	41025	41026	41027	41028
A (m)	1320	1320	1320	1320	1420	1420	1420
A (ft)	4'4"	4'4"	4'4"	4'4"	4'8"	4'8"	4'8"

	41022	41023	41024	41025	41026	41027	41028	41024 +J903	41024 +J904	41025 +J903	41025 +J904	41026 +J903
<b>Momento di sollevamento massimo</b> Maximum lifting moment	kNm 382	365	362	356	347	342	339	-	-	-	-	-
	tm 39,0	37,2	36,9	36,3	35,4	34,9	34,6	-	-	-	-	-
<b>Sbraccio oleodinamico</b> Maximum hydraulic reach												
orizzontale - horizontal	m 7,80	9,90	12,10	14,60	16,65	19,10	21,45	20,20	22,00	22,45	24,25	24,40
verticale - vertical	m 11,45	13,55	15,70	18,00	20,20	22,50	24,90	23,95	25,75	26,20	27,95	27,60
<b>Sbraccio con prolunghe</b> Maximum reach with manual extensions												
orizzontale - horizontal	m 12,10	16,65	21,45	23,95	23,95	23,95	23,95	25,15	25,15	27,40	27,40	28,00
verticale - vertical	m 15,85	20,30	25,10	27,60	27,60	27,60	27,60	29,40	29,40	31,70	31,70	31,70
<b>Impianto oleodinamico - Hydraulic system</b> portata raccomandata - recommended oil flow	l/min 45	45	45	45	45	45	45	45	45	45	45	45
pressione massima - rated pressure	Mpa 29	29	29	29	29	29	29	29	29	29	29	29
capacità del serbatoio - tank capacity	l 200	200	200	200	200	200	200	200	200	200	200	200
<b>Gruppo di rotazione - Slewing system</b> angolo di rotazione - slewing angle	° 400	400	400	400	400	400	400	400	400	400	400	400
coppia di rotazione - slewing moment	kNm 40	40	40	40	40	40	40	40	40	40	40	40
pendenza massima di lavoro - max. working heel	%(°) 8,7(5)	8,7(5)	8,7(5)	8,7(5)	8,7(5)	8,7(5)	8,7(5)	0	0	0	0	0
<b>Peso della gru standard - Standard crane weight</b> Con serbatoio non rifornito - Empty oil tank	Kg 4335	4575	4820	5040	5240	5405	5550	5790	5870	5990	6070	5985
<b>Versione LC - LC version</b> Con serbatoio non rifornito - Empty oil tank	Kg 4490	4730	4975	5195	5395	5560	5705	5945	6025	6145	6225	6140

Tutte le gru PM sono coperte da polizza assicurativa internazionale per la responsabilità civile verso terzi  
 All PM Cranes are covered by international insurance policy for civil liability third party  
 I dati tecnici possono essere aggiornati senza preavviso - Technical data can be revised without prior notice

# [41 s][41 s]<sup>LC</sup>



### 41022 S

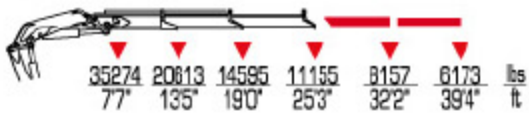

### 41023 S



### 41024 S

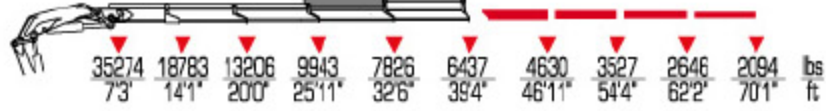

### 41025 S



### 41026 S

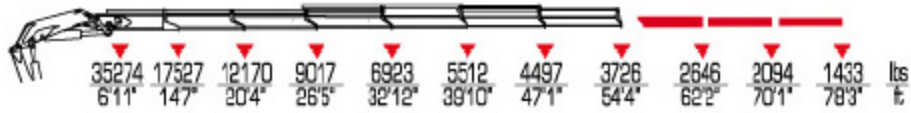

### 41027 S

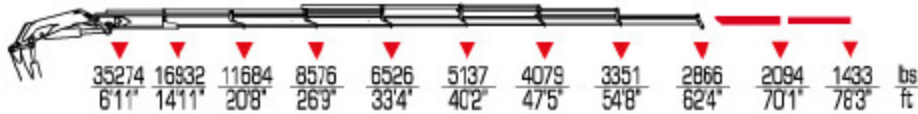

### 41028 S

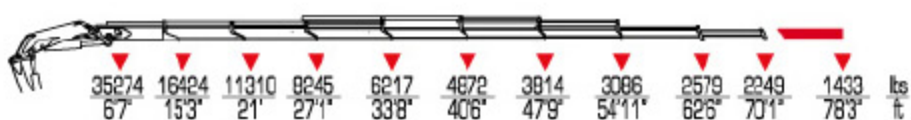

### 41024 S + J903



### 41024 S + J904



### 41025 S + J903

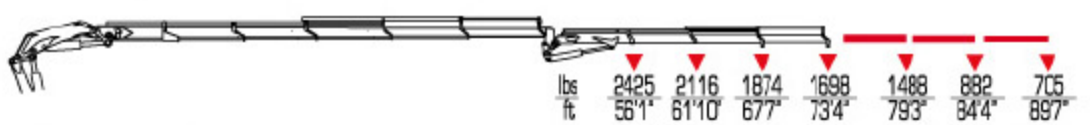

### 41025 S + J904

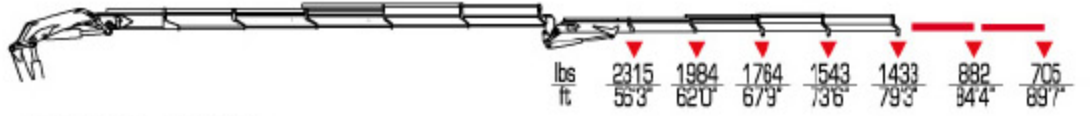

### 41026 S + J703



	ft lbs	gals /min	Psi	°	lbs	ST	LC	84"	8'1"	44"	
<b>41022 S</b>	282090	12	4210	400	9568	9899	84"	8'1"	44"	<b>41022 S</b>	
<b>41023 S</b>	269070	12	4210	400	10141	10472	84"	8'1"	44"	<b>41023 S</b>	
<b>41024 S</b>	266900	12	4210	400	10648	10979	84"	8'1"	44"	<b>41024 S</b>	
<b>41025 S</b>	262560	12	4210	400	11133	11464	84"	8'1"	44"	<b>41025 S</b>	
<b>41026 S</b>	256050	12	4210	400	11552	11883	84"	8'1"	44"	<b>41026 S</b>	
<b>41027 S</b>	252430	12	4210	400	11905	12236	84"	8'1"	44"	<b>41027 S</b>	
<b>41028 S</b>	250260	12	4210	400	12236	12566	84"	8'1"	44"	<b>41028 S</b>	
<b>41024 S + J903</b>	-	12	4210	400	12478	12809	84"	8'11"	48"	<b>41024 S + J903</b>	
<b>41024 S + J904</b>	-	12	4210	400	12655	12985	84"	8'11"	48"	<b>41024 S + J904</b>	
<b>41025 S + J903</b>	-	12	4210	400	12963	13294	84"	8'11"	48"	<b>41025 S + J903</b>	
<b>41025 S + J904</b>	-	12	4210	400	13140	13470	84"	8'11"	48"	<b>41025 S + J904</b>	
<b>41026 S + J703</b>	-	12	4210	400	12820	13151	84"	8'11"	48"	<b>41026 S + J703</b>	