



SILVER

		18023 S	18024 S	18025 S	18026 S	18024 S +J502	18024 S +J503	18025 S +J502	18025 S +J503	18026 S +J252
Maximum lifting moment Momento del elevación máxima	ft lbs	113920	110000	106610	103500	-	-	-	-	-
Maximum hydraulic reach Alcance hidráulico máximo horizontal - horizontal vertical - vertical	ft	34'3"	41'10"	49'5"	57'1"	62'0"	66'7"	69'1"	74'8"	75'7"
	ft	47'5"	54'8"	62'4"	70'1"	74'10"	80'9"	82'6"	88'3"	88'5"
Maximum reach with manual extensions Alcance máximo con prolongas manuales horizontal - horizontal vertical - vertical	ft	-	-	-	72'0"	77'9"	77'9"	85'6"	85'10"	-
	ft	-	-	-	84'8"	90'7"	90'7"	98'3"	98'7"	-
Hydraulic system - Sistema hidráulico recommended oil flow - caudal requerido rated pressure - presión máxima tank capacity - capacidad del depósito de aceite	gals/min	11	11	11	11	11	11	11	11	11
	Psi	4350	4350	4350	4350	4350	4350	4350	4350	4350
	Gals	41	41	41	41	41	41	41	41	41
Slewing system - Sistema de giro slewing angle - ángulo de giro slewing moment - momento de giro max. working heel - inclinación máxima de trabajo	°	408	408	408	408	408	408	408	408	408
	ft lbs	16960	16960	16960	16960	16960	16960	16960	16960	16960
	%(°)	8,7(5)	8,7(5)	8,7(5)	8,7(5)	0	0	0	0	0
Standard crane weight - Peso de la grúa est Empty oil tank - depósito de aceite vacío LC version - LC version Empty oil tank - depósito de aceite vacío	lbs	5390	5721	5997	6228	6878	6989	7220	7330	7264
	lbs	5677	6008	6283	6515	7165	7275	7507	7617	7551

Brought to you by:
American PM Crane Imports Inc.
Phone# (877) MY-PM-CRANE
(877) 697-6272
Or# (407) 246-1642
Dealer Inquiries Welcome:
Email: CorInq@PMCranes.Com

[18 s] PM



SILVER

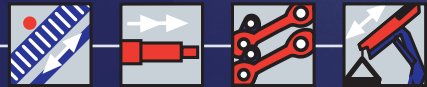

[elevate to the highest power] PM

[18 s] PM

EN12999

IN ACCORDANCE TO THE EU SAFETY STANDARDS
CONFORME CON LAS NORMAS DE SEGURIDAD EU

- PM crane in LC version, with first hydraulic retractable boom, optimizes the load positioning close to the column, and makes easy the placement of heavy and bulky loads.
- En la versión LC, el primero brazo se recoge hidráulicamente, así que permite de elevar, mover y también colocar material pesado y de grande tamaño cerca de la columna.

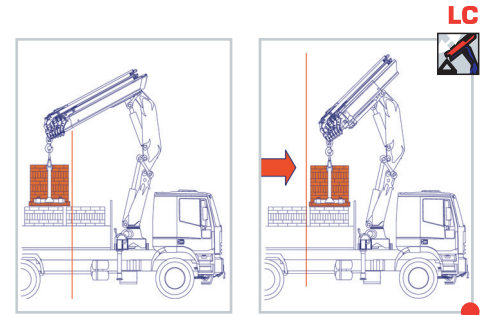

[IIA]

DECLARATION OF CONFORMITY OF THE MANUFACTURER
DECLARACIÓN DE CONFORMIDAD DEL PRODUCTOR



- DOUBLE LINKAGE ON THE POINTS OF ARTICULATION TO ENSURE CONSTANT AND ACCURATE MOVEMENTS.
- DOBLES BIELAS EN LAS ARTICULACIONES PARA MOVIMIENTOS CONSTANTES Y DE PRECISIÓN.

[3]

3 YEARS OF WARRANTY ON THE STRUCTURAL PARTS
3 AÑOS DE GARANTÍA POR LAS PARTES ESTRUCTURALES

new



- Stabilising system consisting of a control valve block with levers.
- Sistema de estabilización mediante distribuidor hidráulico de palancas



SILVER

new

- The main boom can reach a negative angle of 12°: this allows for better control over the load, by balancing the flexure of hydraulic extensions.
- El brazo principal puede asumir un ángulo negativo de 12°: permite un mejor control de la carga equilibrando las flexiones de las extensiones hidráulicas.



optional

- Hydraulic jib available with 2 and 3 extensions
- Jib con 2 y 3 extensiones

PQS

**CERTIFIED PAINTING QUALITY SYSTEM
SISTEMA DE BARNIZADO DE CALIDAD CERTIFICADA**

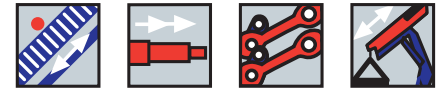

PM TRONIC
Power **COMPACT**

- MAXIMUM CONTROL thanks to the PM Power Tronic Compact electronic system.
- MÁXIMO PODER DE CONTROL gracias al sistema electrónico PM Power Tronic Compact.

- UP TO 6 HYDRAULIC EXTENSIONS
- AVAILABLE with sequential extension exit device guaranteed for maximum speed and protection of integrity of the jib itself.
- DISPONIBLE HASTA 6 EXTENSIONES HIDRÁULICAS con dispositivo de salida de las extensiones en secuencia, garantizado para la máxima velocidad y para proteger la integridad del brazo.

CDS



Slewing by rack
Rotación con cremallera de giro



Extension sequence boom
Salida secuencial de los brazos



Double connecting rods
Doble biela



LC execution
Configuración LC

- CDS (Controlled Downstroke System): it guarantees a controlled and vibration-free downstroke thanks to the valves with low pressure control function which are not affected by pressure caused by the load.
- CDS (Controlled Downstroke System): garantiza un movimiento de bajada controlada y sin oscilaciones gracias a las válvulas con control en baja presión, que no sufren del peso cargado.



PM



[en]

The Power Tronic Compact is a high-performance electronic control system designed to replace moment limiting devices.

Thanks to its sophisticated "Wave Tracking" software (developed by PM's R&D department), the Power Tronic Compact offers an enhanced execution, implementing all its functions by means of pressure and motion sensors.

[es]

Power Tronic Compact es el sistema de control electrónico que sustituye el limitador de momento hidráulico a fin de garantizar elevadas prestaciones. Gracias a un sofisticado software de "Seguimiento de onda" (desarrollado por la sección I&D de PM) el Power Tronic Compact desempeña de forma optimizada todas las funciones por medio de sensores de presión y movimiento.

PM POWER TRONIC COMPACT

[en]

- Fewer hydraulic links
- Better handling in all operating conditions
- Real-time diagnostics with backlit LCD unit displaying crane status and/or error messages
- Wire-to-Wire system: all the connections between the ECUs and the sensors are direct and use automotive components only (protection degree IP66)
- Smart satellite at dual control end: all series equipped with the Power Tronic Compact come with a satellite at the dual control end as standard. This device repeats all the crane control and monitoring functions issued by the main control unit.

[es]

- Advanced work area management: this option allows two different work areas to be handled at the same time, ensuring work is always carried out in the utmost safety, even over the truck cab.

- Reducción de los enlaces hidráulicos.
- Mayor libertad de maniobra en todas las situaciones operativas.
- Diagnóstico en "Tiempo Real" que, mediante el display de cristales líquidos retroiluminado, muestra los mensajes de estado y/o de error de la grúa.
- Cableados eléctricos "Wire to Wire": todas las conexiones entre las

centralitas electrónicas y los sensores son de tipo directo y cuentan con componentes de tipo "automotive" y grado de protección IP66.

- Satélite "inteligente" en el lado del doble mando: todas las series equipadas con Power Tronic Compact están provistas de serie de un satélite en el lado del doble mando que reproduce todas las funciones de gobierno y control del mando principal de la grúa.
- Gestión avanzada de las áreas de trabajo: como opción, es posible gestionar dos diferentes áreas de trabajo a fin de poder operar con máxima seguridad incluso desde la cabina del camión.

[LC]

[en]

LC (Long-Short) TELESCOPIC SYSTEM

The **LC System**, which has become part of the PM range, enables movement of telescopic booms within a 1st boom acting as a sheath. This is done using the same control of the boom extension cylinders and without altering the maximum outreach.

Approaching the column and raising the attachment point by approximately **80 cm** with respect to the loading surface optimises both load handling and positioning. The LC system does not reduce the extension stroke but on the contrary increases it, thus making the crane suitable for any loading position.

[es]

SISTEMA TELESCÓPICO LC (Largo-Corto)

El **Sistema LC**, ya consolidado en la producción de PM, permite el desplazamiento de los brazos telescópicos dentro de un primer brazo a modo de vaina, utilizando el mismo mando de los gatos de esfido de los brazos y dejando invariada la distancia de alcance máximo. El acercamiento a la columna y el levantamiento del punto de enganche unos **80 cm** sobre el plano de carga permite optimizar tanto el desplazamiento como el posicionamiento de la carga. El sistema LC no limita el recorrido del esfido sino que lo amplía, de manera que la grúa resulta adecuada para afrontar cualquier posición de carga.

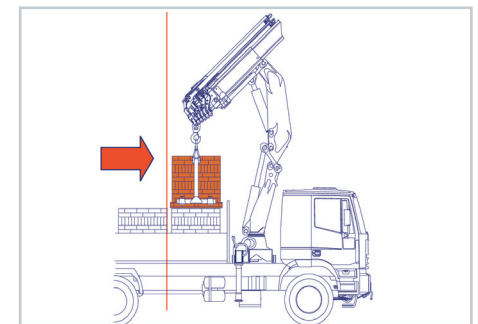

18023 S - 18023 S LC

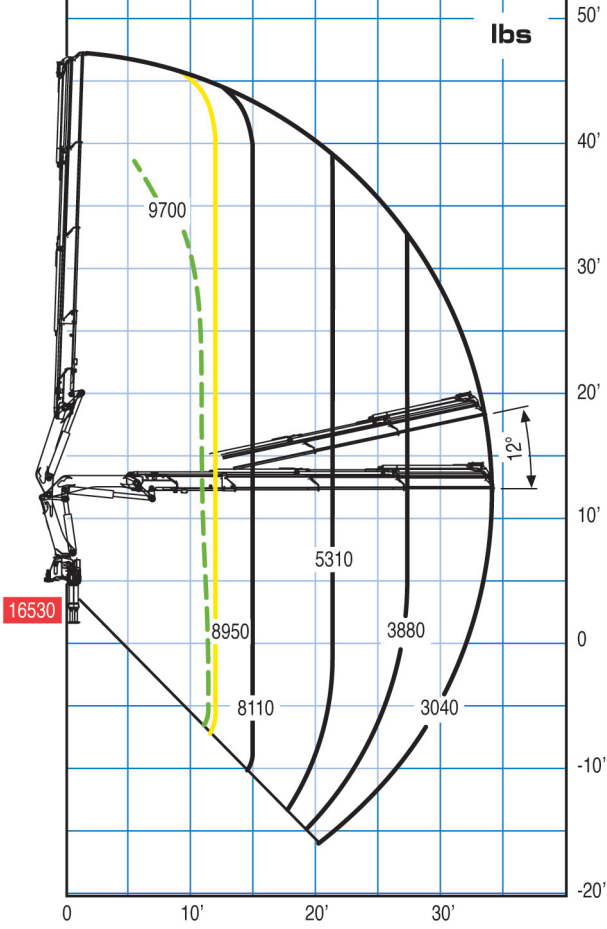

18024 S - 18024 S LC

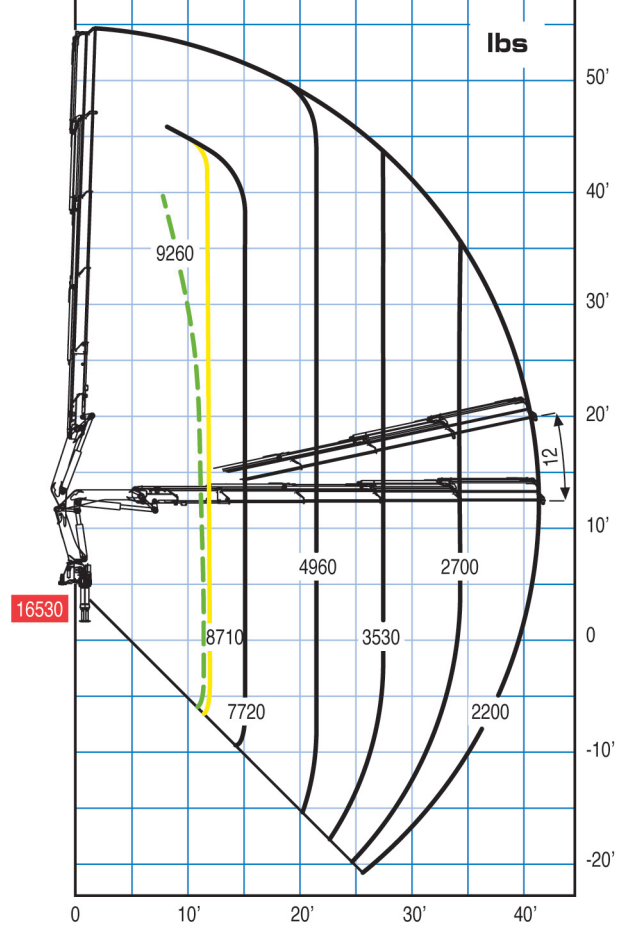

18025 S - 18025 S LC

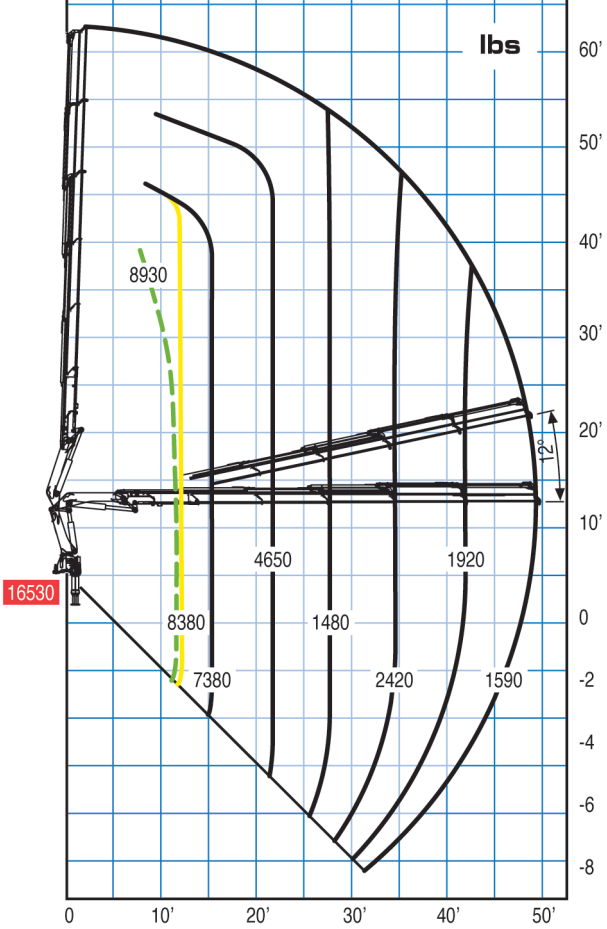

18026 S - 18026 S LC

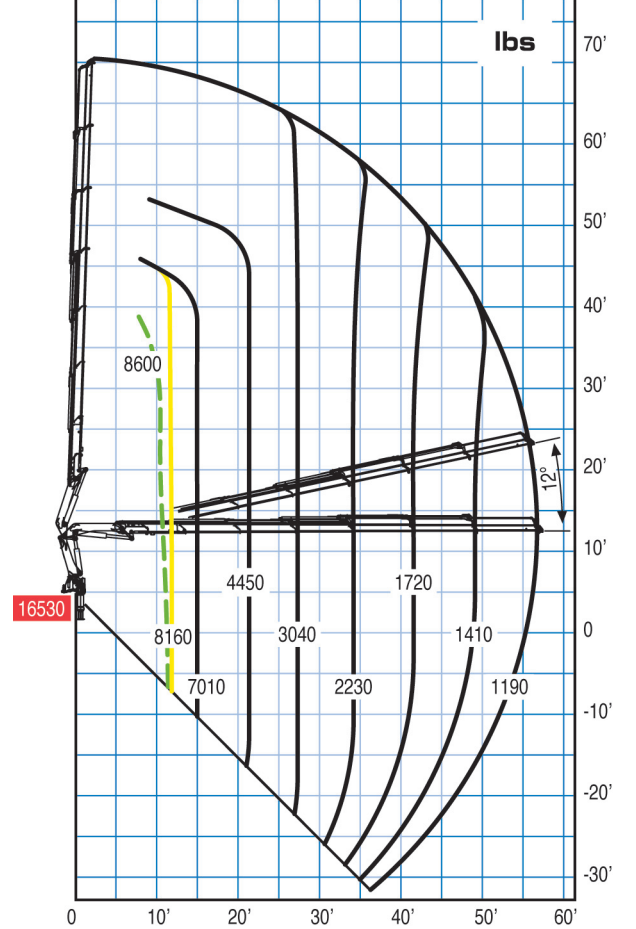

18024 S + J502

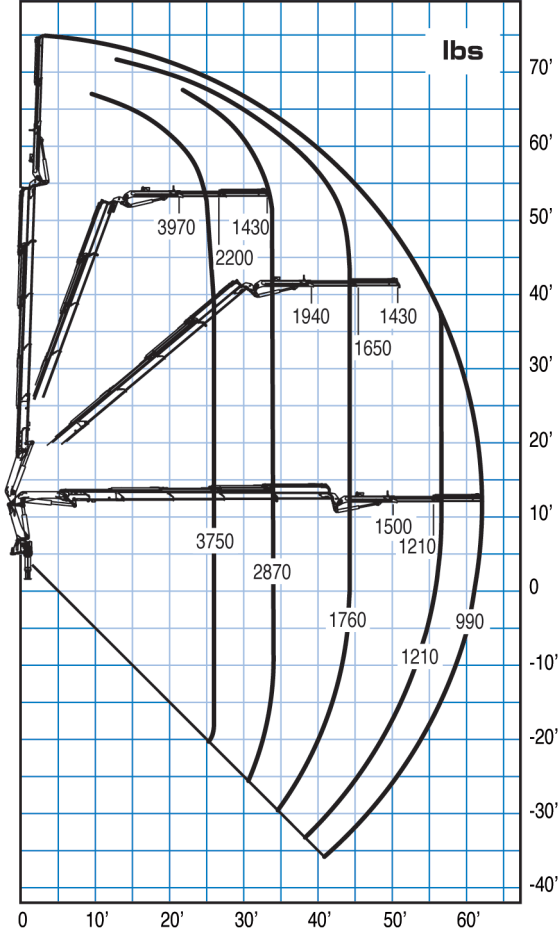

18024 S + J503

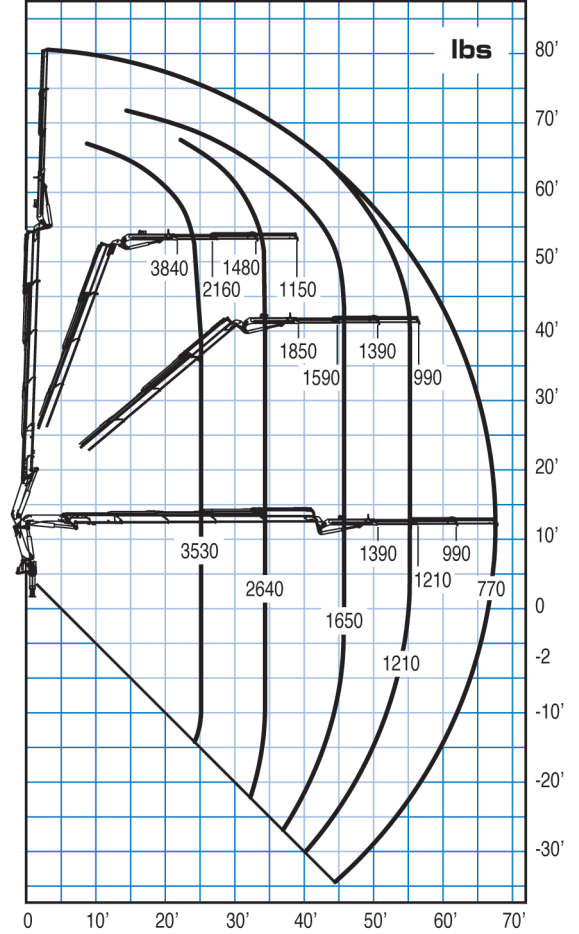

18025 S + J502

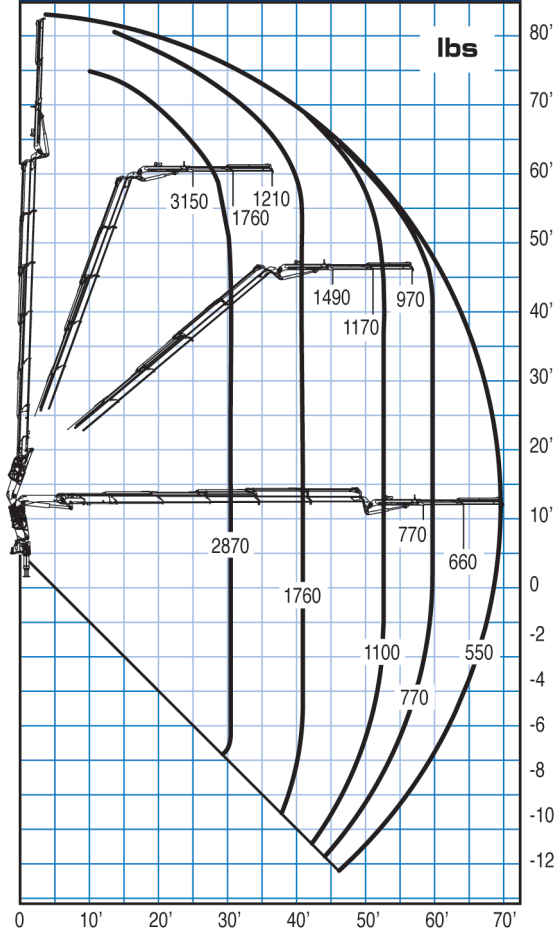

18025 S + J503

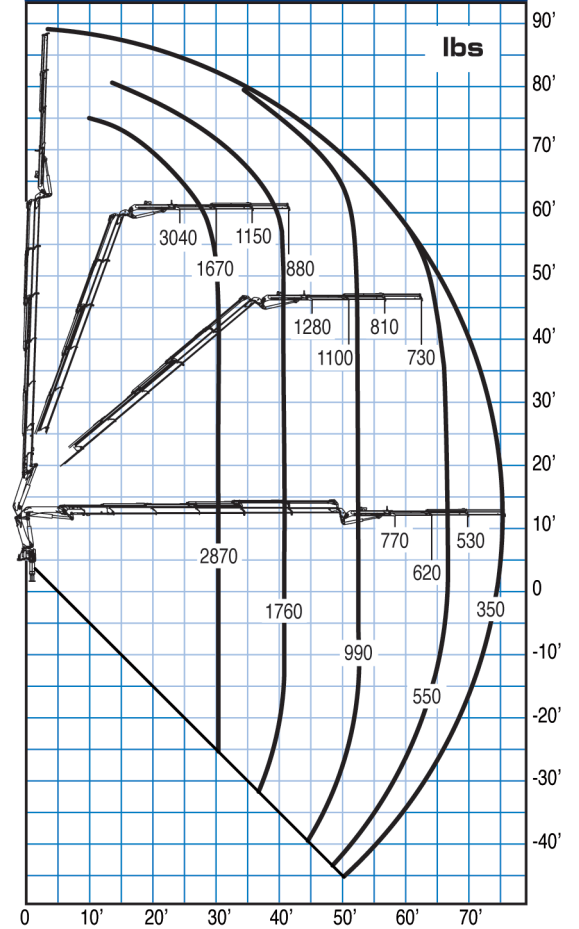

18026 S + J252

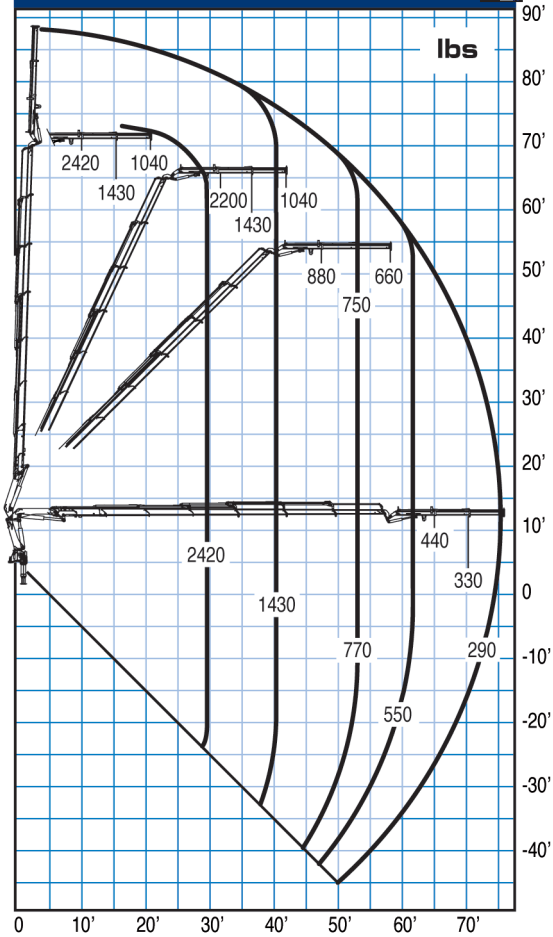

Trucking crane combination - Acoplamiento grúa con vehículo

PTT/GVV	18S
18,0 ton	Blue
19,0 ton	Blue
26,0 ton	Green
32,0 ton	Orange

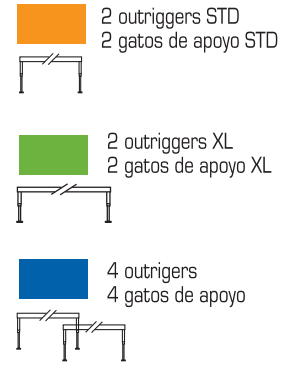

PTT: G.V.W. - Peso total del vehículo

- Max. nominal capacity with fixed hook.
Capacidad máxima en el gancho fijo.
- Max. capacity from horizontal to vertical.
Capacidad máxima en posición vertical.
- - - Only LC crane version
Solo con grúa en versión LC

All PM Cranes are covered by international insurance policy for civil liability third party.
Todas las grúas PM cuentan con una póliza de seguros internacional contra las responsabilidades civiles hacia terceros.

Technical data can be revised without prior notice.
Reservado el derecho de modificaciones.

mm
ft

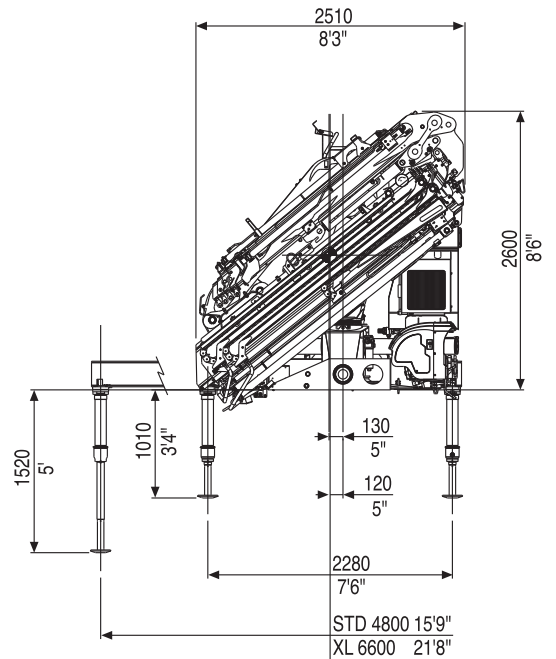
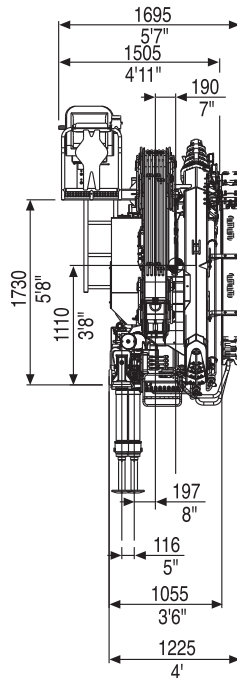
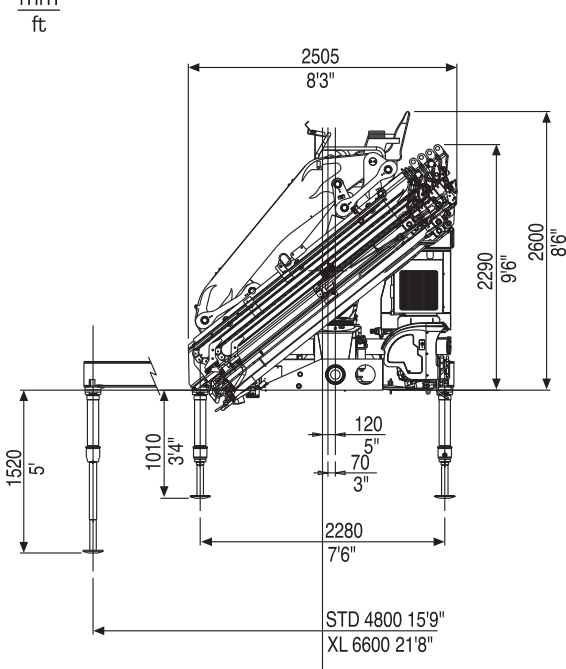

[18 s][18 s]LC

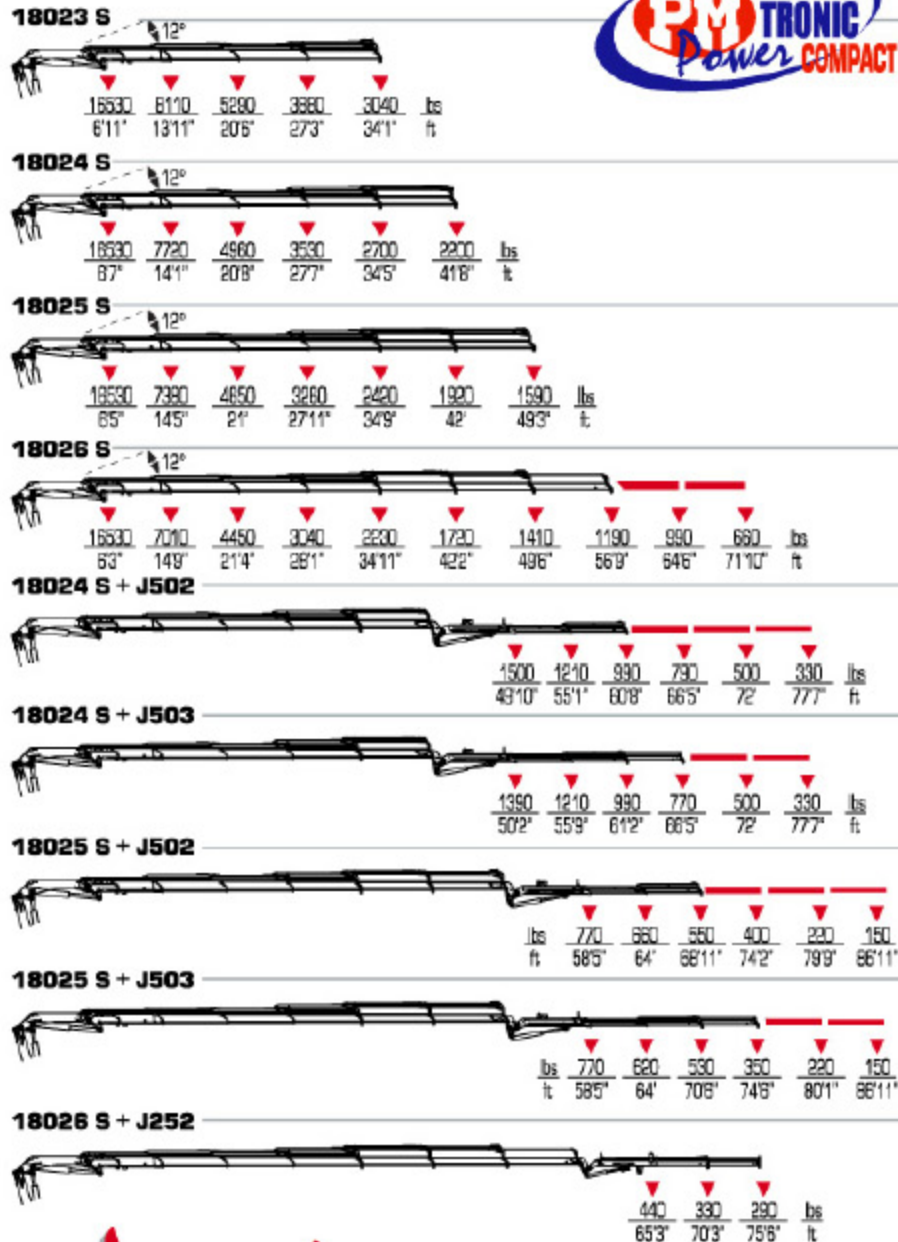

New

18 Ton Articulating Crane Models.

- 18 Ton Articulating Crane Model 18023 S Max Lift 3040 Max Reach 34'1
- 18 Ton Articulating Crane Model 18024 S Max Lift 2200 Max Reach 41'8
- 18 Ton Articulating Crane Model 18025 S Max Lift 1590 Max Reach 49'3
- 18 Ton Articulating Crane Model 18026 S Max Lift 1190 Max Reach 66'0

Jib Crane Models:

- 18 Ton Articulating Crane Model 18024 S + J502 Max Lift 990 Max Reach 60'8
- 18 Ton Articulating Crane Model 18024 S + J503 Max Lift 770 Max Reach 66'5
- 18 Ton Articulating Crane Model 18025 S + J502 Max Lift 550 Max Reach 68'11
- 18 Ton Articulating Crane Model 18025 S + J503 Max Lift 350 Max Reach 74'8
- 18 Ton Articulating Crane Model 18026 S + J252 Max Lift 290 Max Reach 75'6

Our PM Articulating cranes are comparable to all fassi, cormach, hiab, palfinger, atlas, amco veba, heila, jabco or imt cranes.



	ft lbs	gals /min	Psi	°	lbs	ST	LC				
18023 S	113920	11	4130	408	4894	5071	8'3"	7'6"	3'6"		18023 S
18024 S	110000	11	4130	408	5225	5401	8'3"	7'6"	3'6"		18024 S
18025 S	106610	11	4130	408	5512	5688	8'3"	7'6"	3'6"		18025 S
18026 S	103500	11	4130	408	5754	5930	8'3"	7'6"	3'6"		18026 S
18024 + J502	-	11	4130	408	6096	6272	8'3"	8'6"	4'		18024 + J502
18024 + J503	-	11	4130	408	6206	6382	8'3"	8'6"	4'		18024 + J503
18025 + J502	-	11	4130	408	6382	6559	8'3"	8'6"	4'		18025 + J502
18025 + J503	-	11	4130	408	6493	6669	8'3"	8'6"	4'		18025 + J503
18026 + J252	-	11	4130	408	6393	6570	8'3"	8'6"	4'		18026 + J252